

Clamping towers, grey cast iron, 8-sided, with pre-machined clamping faces

Item description/product images



Description

Material:

GJL 300.

Version:

Support and clamping faces are precision-machined.

The clamping faces have a +1 mm allowance.

Note:

Clamping towers with pre-machined clamping faces provide a fast and economic way of producing bodies with specific grid or individual holes. The base is ready for mounting on the machine table. The clamping faces can be machined to the end dimensions by the user. The clamping towers conform to machine tables for machine tools acc. to DIN 55201 and JIS6337-1980.

Please order locating pins for positioning subplates on machine tables acc. to DIN 55201 separately.

Ring bolts for hoisting are supplied.

Other dimensions available on request.

On request:

other dimensions.

Drawing reference:

1) hole for DIN 912 cap screw (D3/D4)

Clamping towers, grey cast iron, 8-sided, with pre-machined clamping faces

Drawings

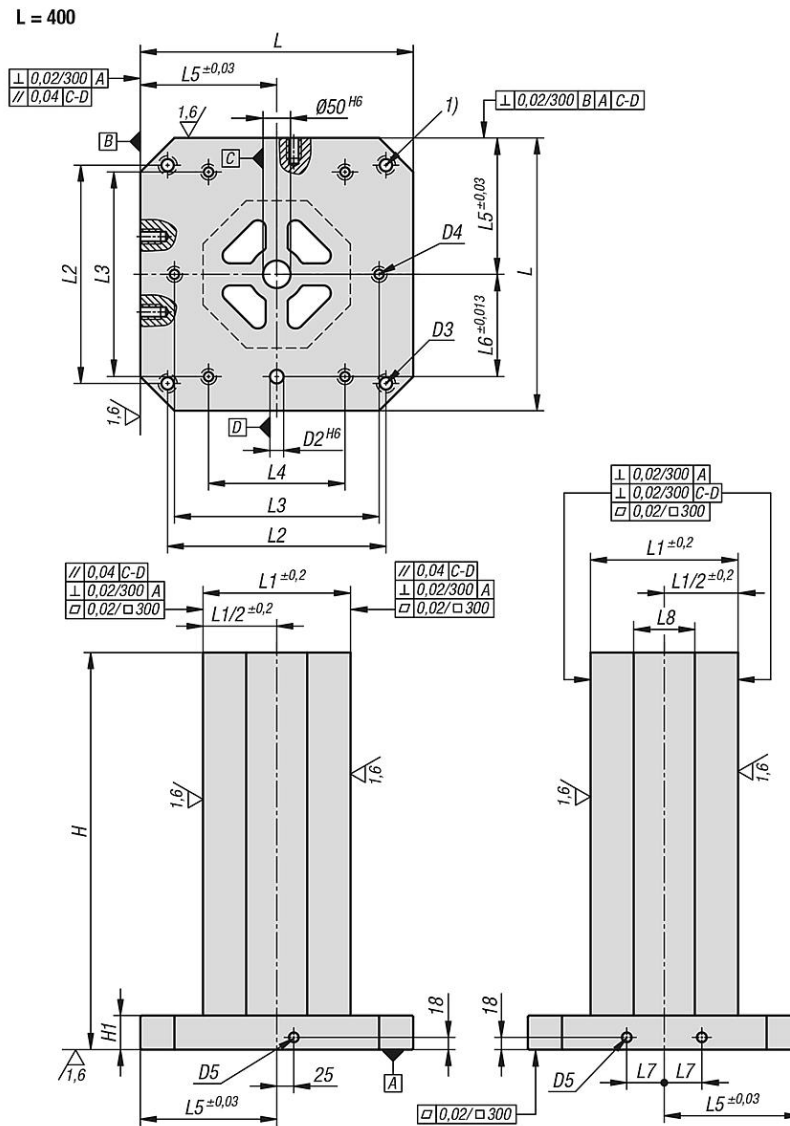

Clamping towers, grey cast iron, 8-sided, with pre-machined clamping faces

Drawings

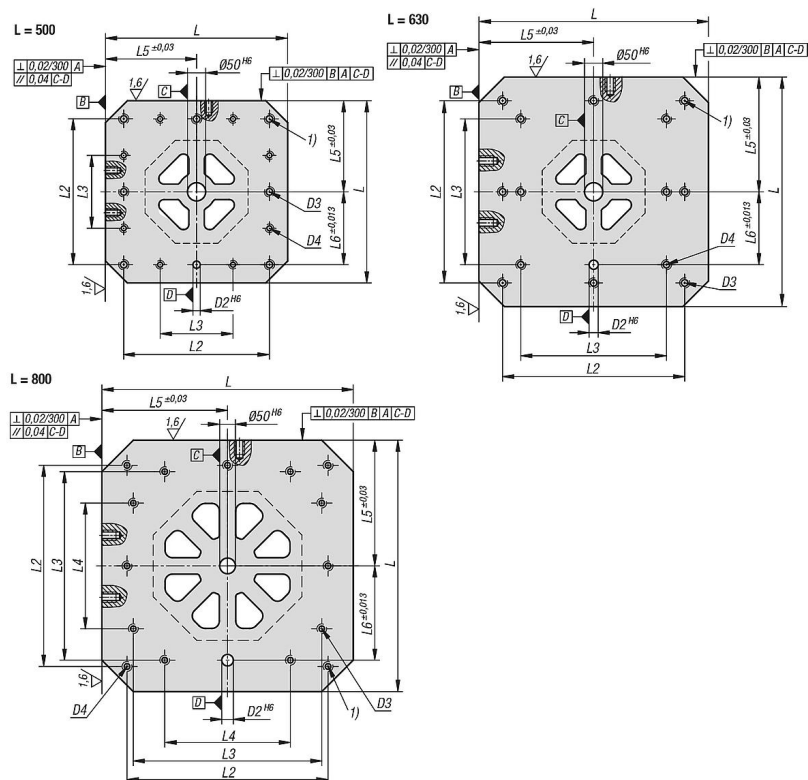

Overview of items

Clamping towers, grey cast iron, 8-sided, with pre-machined clamping faces

Order No.	L	H	H1	D2	D3	D4	D5	L1	L2	L3	L4	L5	L6	L7	L8
K1535.10040050	400	500	50	20	M16	M12	M16	251	320	300	200	200	150	55	103,4
K1535.10040065	400	650	50	20	M16	M12	M16	251	320	300	200	200	150	55	103,4
K1535.10050060	500	600	50	20	M16	M12	M16	301	400	200	-	250	200	75	124,4
K1535.10050075	500	750	50	20	M16	M12	M16	301	400	200	-	250	200	75	124,4
K1535.10063070	630	700	50	25	M16	M16	M16	351	500	400	-	315	200	100	145,4
K1535.10063085	630	850	50	25	M16	M16	M16	351	500	400	-	315	200	100	145,4
K1535.10080080	800	800	50	25	M16	M16	M16	501	640	600	400	400	300	135	207,4
K1535.10080100	800	1000	50	25	M16	M16	M16	501	640	600	400	400	300	135	207,4