

Locating cylinders pneumatic

Item description/product images

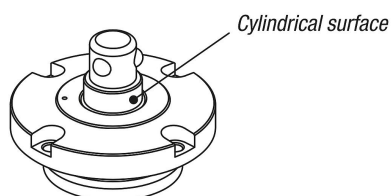
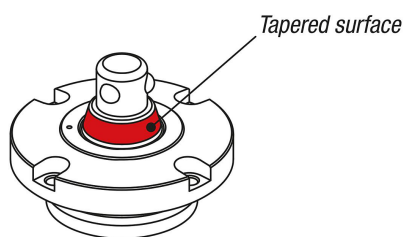
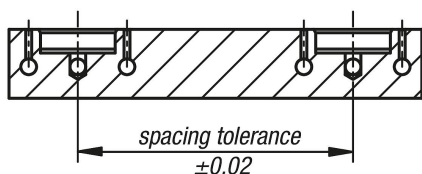

Description

Material:

Housing and clamping cylinder, carbon steel.
Balls, stainless steel 1.0503.

Version:

Housing hardened and black oxidised.
Contact faces ground.

Note:

This positioning and clamping system is especially suitable for installation in fixtures (plates, clamping tower blocks, etc.) in all mounting positions. The modular design allows the number of and distance between the locating cylinders to be ideally adjusted to suit the clamping task. Due to the small diameters, the spacing between the locating cylinders can also be reduced.

The 3 clamping balls are mechanically released through control of the locating cylinder with the "opening" connection. The 3 clamping balls move inward and the fixture can be changed quickly. For clamping, the air is taken from the "opening" connection and the "clamping" connection then receives air on the locating cylinder. The 3 clamping balls are mechanically driven outward again and the new fixture is clamped.

To achieve optimal retaining force, the locating cylinder remains connected to the air.

Locating cylinders pneumatic

Drawings

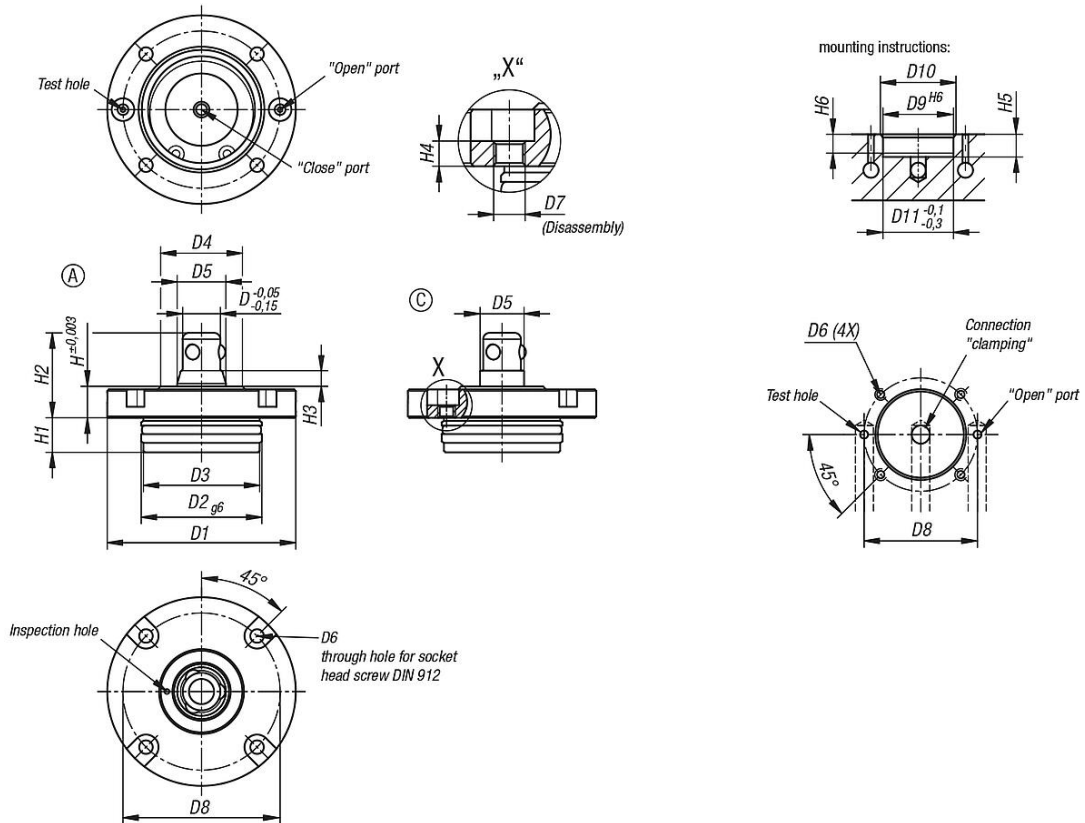

Overview of items

Locating cylinders pneumatic

Order No.	Version 2	Form	D	D1	D2	D3	D4	D5	D6	D7	D8	D9	D10	D11	H	H1	H2	H3	H4	H5	H6	Retaining force F1 N
K1486.11670	conical	A	16	70	48	47,5	38	24,5	M5	M6	60	48	50	48	12	15	35	8	5	16	12	4000
K1486.31670	cylindrical	C	16	70	48	47,5	38	20	M5	M6	60	48	50	48	12	15	35	8	5	16	12	4000
K1486.12085	conical	A	20	85	58	57,5	48	31,5	M6	M8	72	58	60	58	15	19	44	10	6	20	16	6300
K1486.32085	cylindrical	C	20	85	58	57,5	48	26	M6	M8	72	58	60	58	15	19	44	10	6	20	16	6300