

Cylindrical grips safety automatic return

Item description/product images



Description

Material:

Grip black grey thermoplastic.

Version:

Steel parts black oxidised.

Note:

Two actions must be made to bring the safety grip into an operating position:

- Swing the grip out until it stops (90°).
- Push the grip in until it locks.

The pushed-in position is the most comfortable for cranking. The grip swings back automatically after releasing.

Cylindrical grips are supplied assembled and can be screwed onto our handwheels, crank handles etc.

The hole D3 is used for positioning.

Cylindrical grips safety automatic return

Drawings

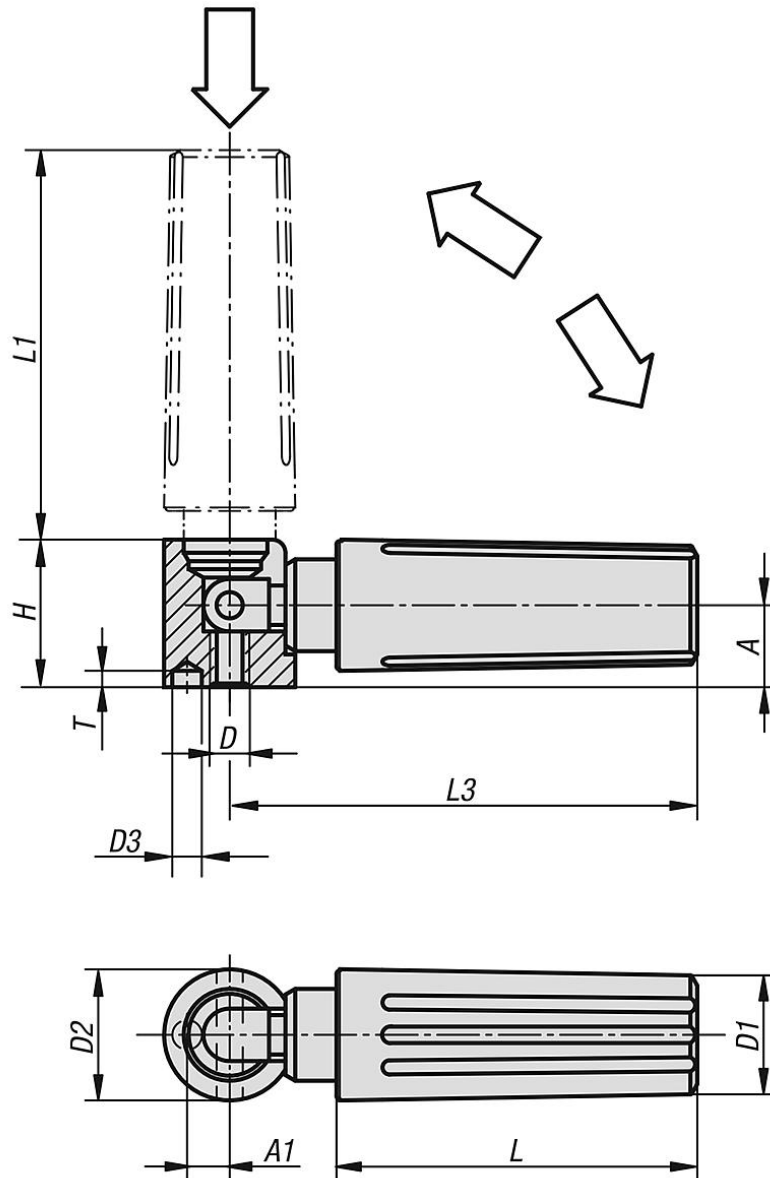

Overview of items

Cylindrical grips safety automatic return

Order No.	A	A1	D	D1	D2	D3	H	L	L1	L3	T
K0265.408	16	9	M8	25	26	5,5	29	70,5	82	98,5	6,5