

Třmenová madla nerezová ocel, oválná

Popis zboží/obrázky produktu



Popis

Materiál:

Třmenové madlo nerezová ocel 1.4404.

Upevňovací materiál 1.4301.

Provedení:

Povrch pololesklý a vyleštěn do hladka.

Výkresy

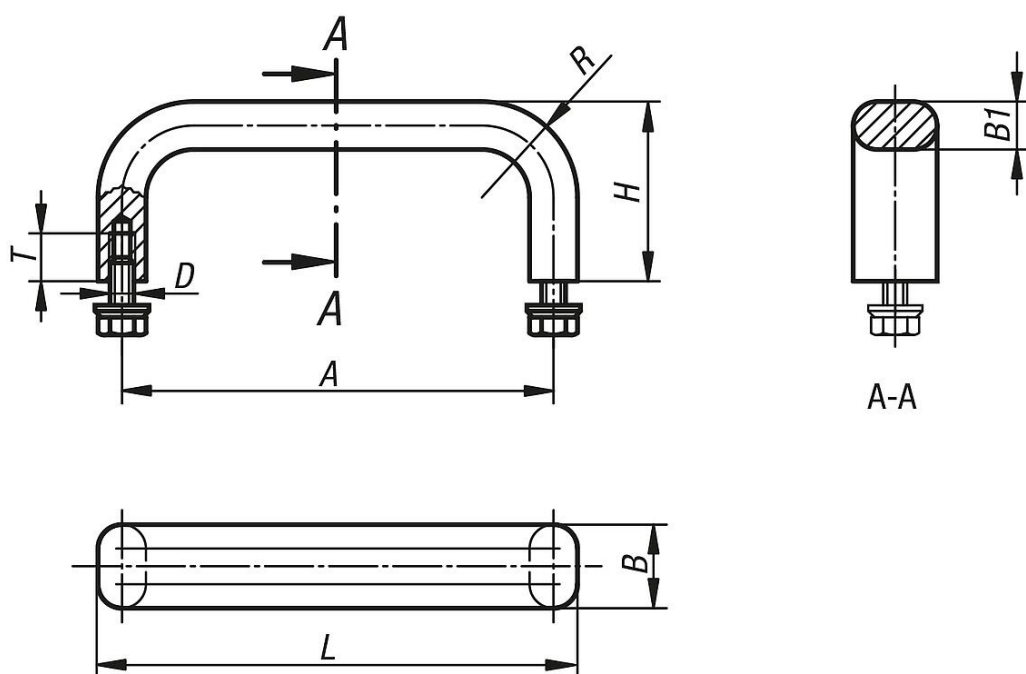

Přehled zboží

Třmenová madla nerezová

Objednací číslo	A	B	B1	D	H	L	R	T	Nosná síla N
K0208.10005	100	12	8	M5x10	40	108	22	10	1000
K0208.12005	120	12	8	M5x10	40	128	22	10	1000
K0208.15005	150	12	8	M5x10	40	158	22	10	1000
K0208.18005	180	12	8	M5x10	40	188	22	10	1000
K0208.25005	250	12	8	M5x10	40	258	22	10	1000
K0208.10006	100	19,5	10	M6x12	45	110	24	12	1000
K0208.12006	120	19,5	10	M6x12	45	130	24	12	1000
K0208.15006	150	19,5	10	M6x12	45	160	24	12	1000
K0208.18006	180	19,5	10	M6x12	45	190	24	12	1000
K0208.25006	250	19,5	10	M6x12	45	260	24	12	1000

