

Ball transfer units undersprung

Item description/product images



Description

Material:

Steel electro zinc-plated.

Note:

Undersprung ball transfer units allow for even distribution of loads for goods with uneven surfaces.

When used in machines such as punch presses and bend form machines the ball rollers spring back up after the forming process and the finished article can be rolled off.

By the "End tension (N)" the ball has completely receded into the housing.

Drawing reference:

- 1) load ball
- 2) bearing balls

Form B: cap and housing electro zinc-plated, balls steel

Form C: cap and housing electro zinc-plated, balls stainless steel

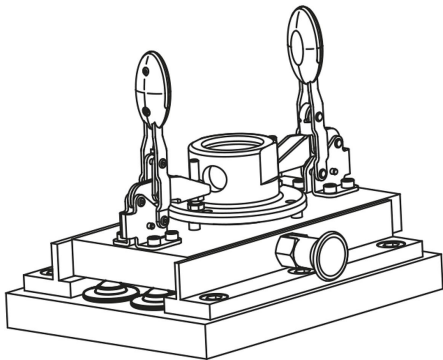
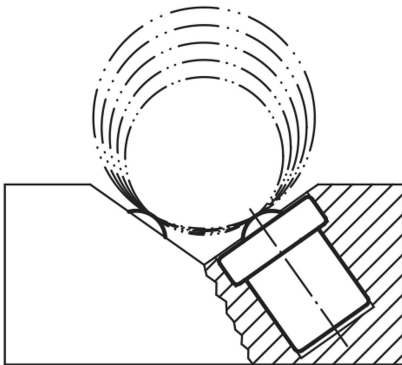

Ball transfer units undersprung

Drawings

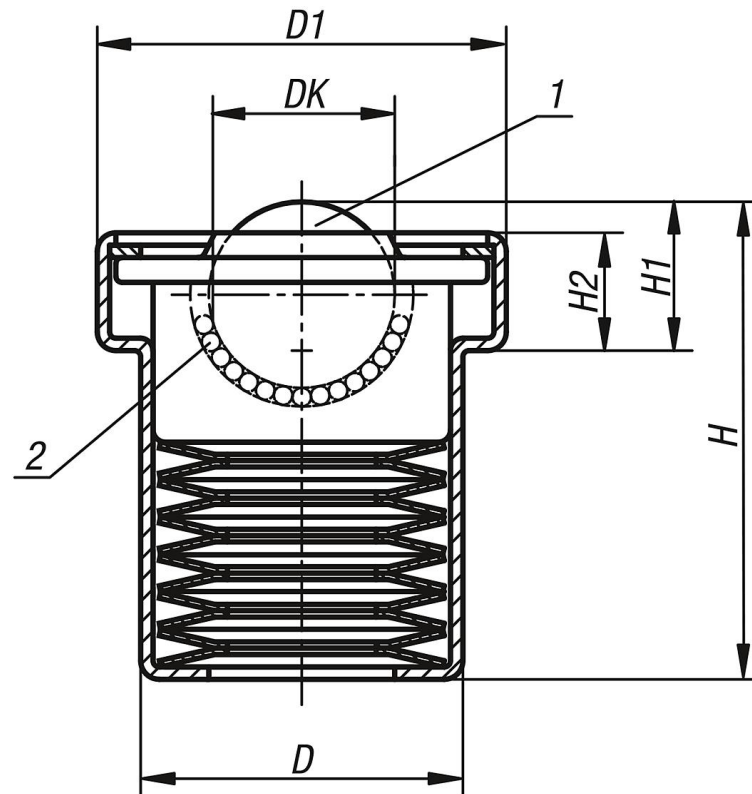

Overview of items

Ball transfer units, undersprung

Order No.	Form	DK	D	D1	H	H1	H2	Pre-tension (N)	End tension (N)	Tol. for pre and end tension (%)
K0762.122	B	22,2	39	50	51,5	18,5	14	730	860	+25 / -7,5
K0762.130	B	30	48,2	62	70	24,4	17,7	1350	1600	+15 / -7,5
K0762.145	B	45	66,4	85	100,5	35,6	24,2	2280	2770	+15 / -7,5
K0762.222	C	22,2	39	50	51,5	18,5	14	730	860	+25 / -7,5
K0762.230	C	30	48,2	62	70	24,4	17,7	1350	1600	+15 / -7,5
K0762.245	C	45	66,4	85	100,5	35,6	24,2	2280	2770	+15 / -7,5