

## Palm grips, high-temperature resistant plastic with protruding steel bush, Form K with tapped bush

Item description/product images



### Description

#### Material:

Thermoplastic PPA (resistant to high temperatures), fibreglass reinforced, black, with FDA, EU10-2011, NSF; KTW conformity.

Metal parts stainless steel 1.4404.

#### Version:

Steel parts bright stainless steel.

#### Note:

Palm grips with projecting steel bush and internal thread are highly suitable for cross pinning.

#### Application:

These palm grips have been specially developed for use in applications with high hygienic and high temperature requirements. The closed grip contour with smooth surfaces are very easy to clean.

For contact with food and potable water this plastic conforms to FDA, EU10/2011, NSF, KTW and have permanent hot water and hydrolysis resistance (steam sterilisation).

This high-temperature plastic is even suitable for permanent use in hot environments while retaining its high strength.

#### Temperature range:

Continuous operating temperature acc. to IEC 216 150 °C - 160 °C max.

Brief use with temperatures up to 250 °C.

#### Advantages:

Resistant to moisture and cleaning agents (by disinfection).

The palm grips can be tightened or loosened without tools.

Suitable for manual fixing and clamping. Various thread sizes.

#### On request:

Special versions.

#### Applications:

For installation on machines, equipment, plants and in areas with increased hygienic requirements.

The target sectors are the foodstuff processing industries (or crafts) where the operating parts come into contact with foodstuff or potable water.

These palm grips are suitable for use by special applications with very high environmental temperatures, with permanent hot water or steam contact.

## Palm grips, high-temperature resistant plastic with protruding steel bush, Form K with tapped bush

Drawings

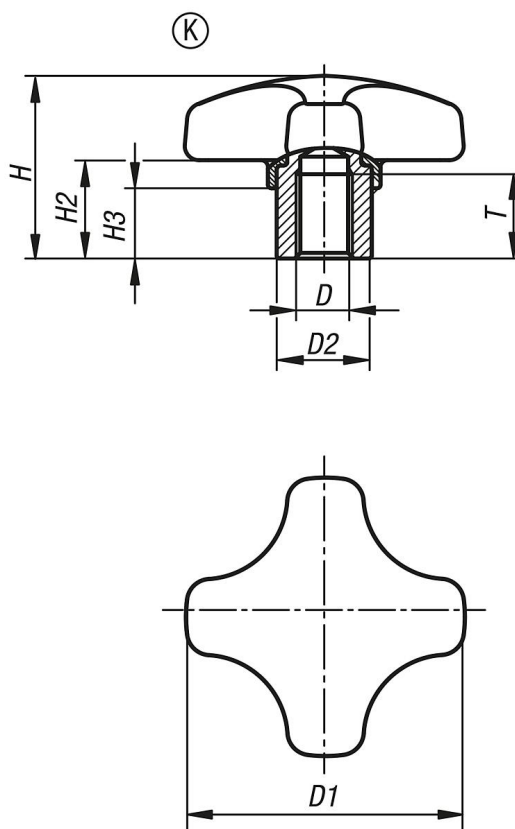

### Overview of items

Order No.	Form	Component material	Surface finish component	Main colour	D	D1	D2	H	H2	H3	T	Approval / Certification
K1794.152505390	K	stainless steel	bright	black	M5	25	10	18	9	7	9	FDA + EU10/2011 + NSF
K1794.153206390	K	stainless steel	bright	black	M6	32	13,5	22	12	9,5	12	FDA + EU10/2011 + NSF
K1794.154006390	K	stainless steel	bright	black	M6	40	13,5	26	14	10	12	FDA + EU10/2011 + NSF
K1794.154008390	K	stainless steel	bright	black	M8	40	13,5	26	14	10	12	FDA + EU10/2011 + NSF
K1794.155008390	K	stainless steel	bright	black	M8	50	19	32	18	12	17	FDA + EU10/2011 + NSF
K1794.155010390	K	stainless steel	bright	black	M10	50	19	32	18	12	17	FDA + EU10/2011 + NSF