

Locating cylinder stainless steel Ball Lock

Item description/product images



Description

Material:

Locating cylinder and ball stainless steel 1.4542.

Version:

Locating cylinder and ball hardened to min. 40 HRC, bright.

Note:

By tightening the thrust screw (D2) the centre ball is pressed downwards and in turn forces the three locking balls outwards, where they locked in the receiver bush. With this easy to use system machine set-up times are up to twelve times shorter than when conventional methods are used.

Locating cylinder stainless steel Ball Lock

Drawings

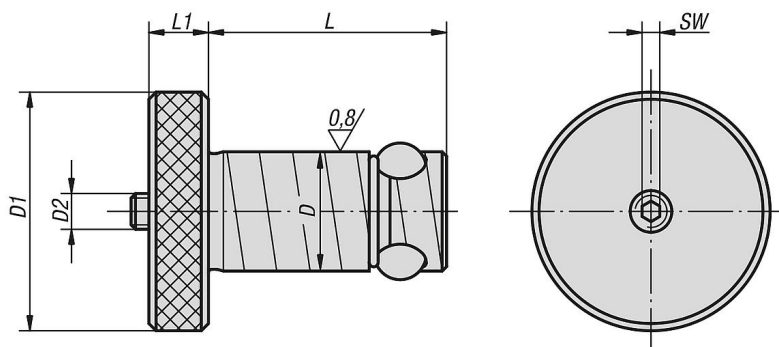

Overview of items

Locating cylinder stainless steel Ball Lock

Order No.	Grid plate thickness ± 0.13	D	D1	D2	L	L1	SW	Holding force F kN	Tightening torque max. Nm	Order No. Repair Kit
K1474.13013	13	13	22	M5	27,6	6	2,5	3,3	1,2	K1474.913013
K1474.13020	20	13	22	M5	34,6	6	2,5	3,3	1,2	K1474.913020
K1474.16020	20	16	32	M6	36,5	8	3	5,3	4,5	K1474.916020
K1474.16025	25	16	32	M6	41,5	8	3	5,3	4,5	K1474.916025
K1474.20020	20	20	40	M6	39,5	10	3	13,3	5,3	K1474.920020
K1474.20025	25	20	40	M6	44,4	10	3	13,3	5,3	K1474.920025
K1474.25020	20	25	45	M8	44	10	4	30	11	K1474.925020
K1474.25025	25	25	45	M8	49	10	4	30	11	K1474.925025
K1474.30020	20	30	50	M10	49	13	5	44	18	K1474.930020
K1474.30025	25	30	50	M10	54	13	5	44	18	K1474.930025
K1474.35020	20	35	60	M12	51	13	6	68	33	K1474.935020
K1474.35025	25	35	60	M12	56	13	6	68	33	K1474.935025
K1474.35040	40	35	60	M12	71	13	6	68	33	K1474.935040
K1474.35050	50	35	60	M12	81	13	6	68	33	K1474.935050
K1474.50020	20	50	75	M20	64	20	10	88	65	K1474.950020
K1474.50025	25	50	75	M20	69	20	10	88	65	K1474.950025
K1474.50040	40	50	75	M20	84	20	10	88	65	K1474.950040
K1474.50050	50	50	75	M20	94	20	10	88	65	K1474.950050