

UNILOCK 5-axis add-on module system size 50 mm

Item description/product images



Description

Material:

Body Q&T steel.
Clamping pin mild steel.

Version:

Main body oxidised.
Contact faces hardened and ground.

Note:

UNIlock 5-axis add-on clamp modules are used for raising basic modules and mounting bases.
Depending on the clamping situation, optimum assembly height can be achieved using a combination of basic module and add-on module.
The add-on clamping module system size 50 can also be combined with system size 80.

The following clamping forces are possible with the UNILOCK clamping pin in conjunction with M8, M10 fastening screws:

- Clamping force (M8) 15,000 kN
- Clamping force (M10) 25,000 kN

Clamping force with DIN EN ISO 4762 -12.9 cap screws

Clamping pins may only be clamped in conjunction with a mounted interchangeable unit in the clamping module.

UNILOCK 5-axis add-on module system size 50 mm

Drawings

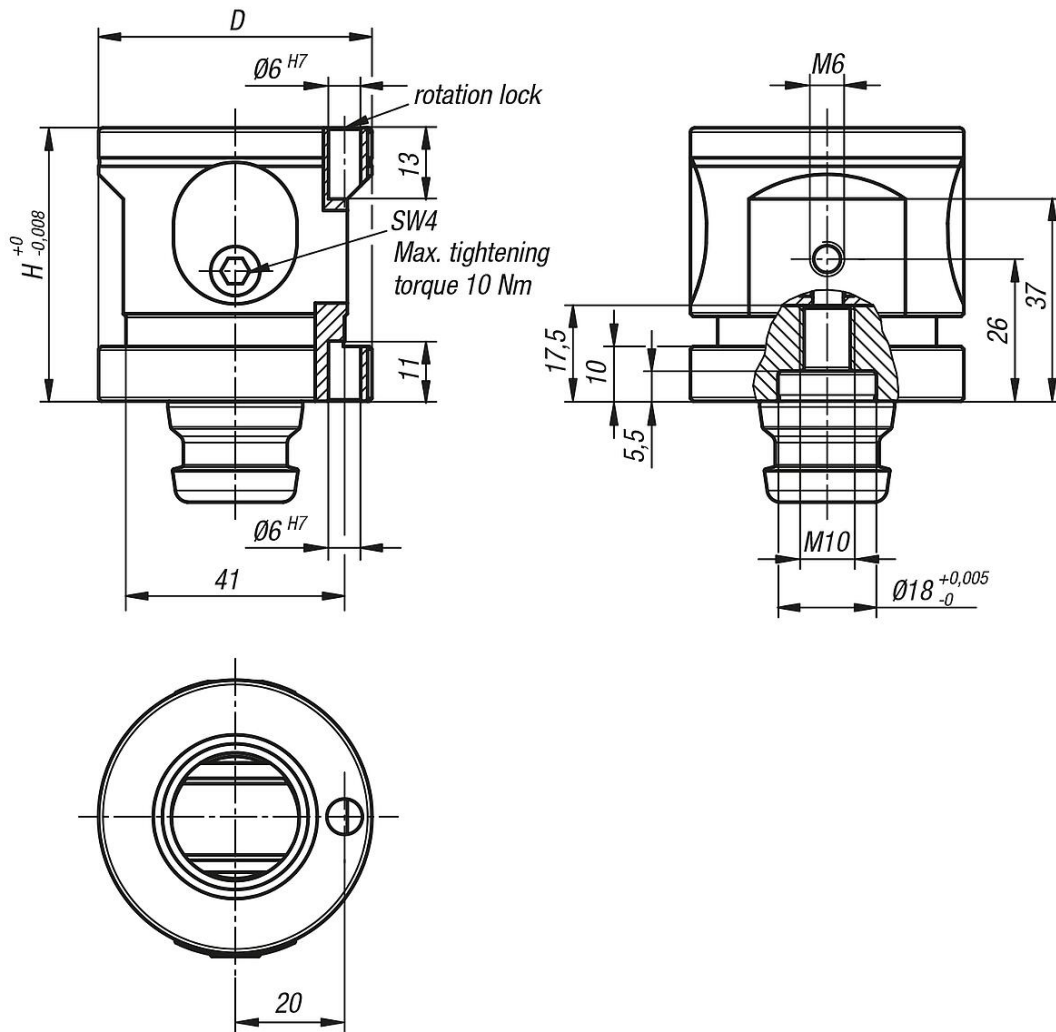

Overview of items

UNILOCK 5-axis add-on module, system size 50 mm

Order No.	Form	Form definition	D	H	SW	Retraction force kN	Tightening torque max. Nm
K1119.0501	B	with rotation lock	50	50	4	10	10