

Centring pins for central hole

Item description/product images



Description

Material:
Steel.

Version:
Case-hardened.
Toleranced diameter ground.

Note:
Centring pins for central holes are suitable for basic elements K0806, K0803, K0804 and K0805.

Drawings

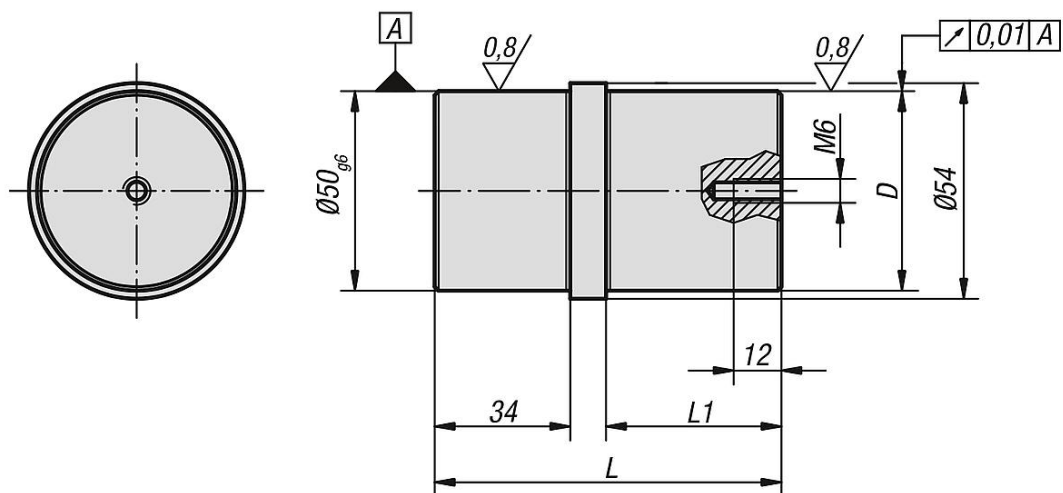

Overview of items

Centering pins for central hole

Order No.	D	L	L1
K0856.5025	25 g6	77	34
K0856.5030	30 h6	87	44
K0856.5050	50 g6	87	44

