

Clamping balls with cup for workpiece stabiliser

Item description/product images



Description

Material:
Steel.

Version:
DIN EN ISO 4017 hex head bolt , grade 8.8, black.
DIN EN ISO 4762 cap screw grade 8.8, black.
Clamping ball bright.

Note:
The clamping balls enable flexible connections between the workpiece and the workpiece stabiliser. The clamping balls provide a high degree of freedom on the workpiece.

Drawing reference:
1) DIN EN ISO 4762 cap screw

Drawings

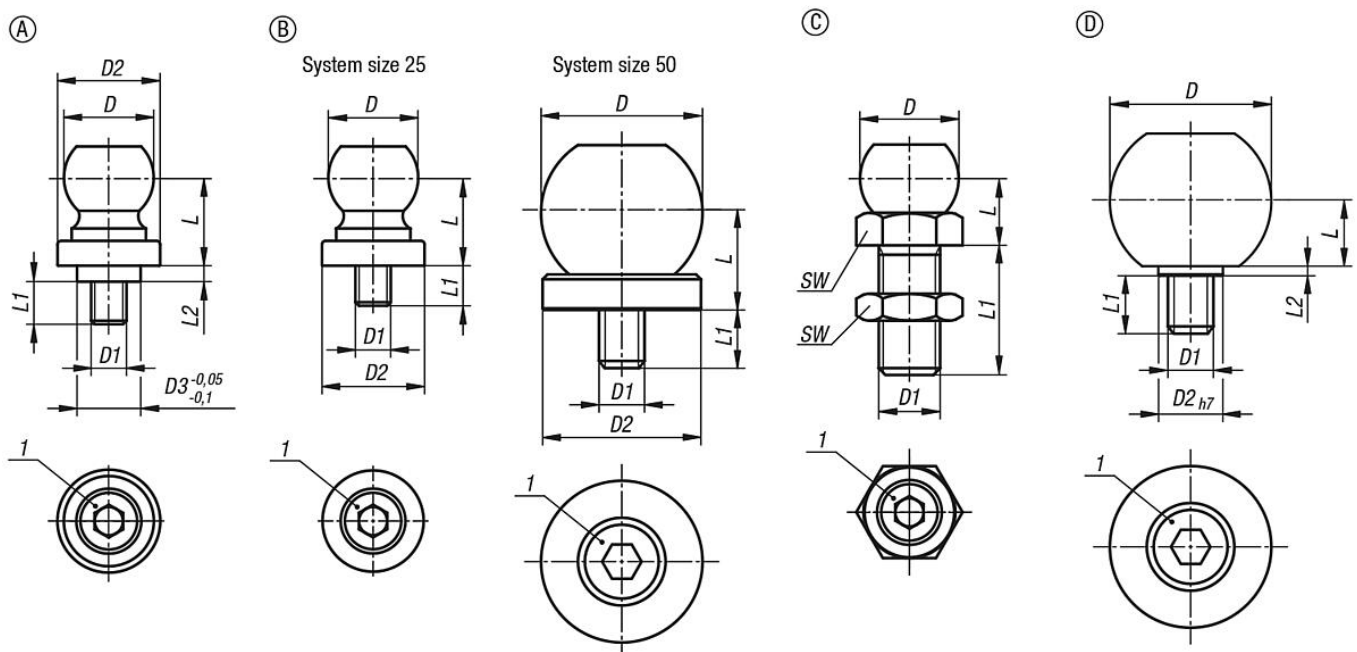

Overview of items

Clamping balls with cup for workpiece stabiliser

Order No.	Form	Size	D	D1	D2	D3	L	L1	L2	SW
K1193.125	A	25	25,4	M10	29	18	25	12,2	4,5	-
K1193.225	B	25	25,4	M10	29	-	25	11	-	-
K1193.250	B	50	50	M16	49	-	30	20,5	-	-
K1193.3251240	C	25	25,4	M12	-	-	17,3	40	-	18
K1193.3251640	C	25	25,4	M16	-	-	19,8	40	-	24
K1193.3252050	C	25	25,4	M20	-	-	22,3	50	-	30
K1193.3252450	C	25	25,4	M24	-	-	24,8	50	-	36
K1193.3502450	C	50	50	M24	-	-	34,5	50	-	36
K1193.3503060	C	50	50	M30	-	-	34,5	60	-	46

Clamping balls with cup for workpiece stabiliser

Overview of items

Order No.	Form	Size	D	D1	D2	D3	L	L1	L2	SW
K1193.3503670	C	50	50	M36	-	-	34,5	70	-	55
K1193.450	D	50	50	M16	25	-	20	18	3,5	-