

Threaded bushings for grid systems

Item description/product images

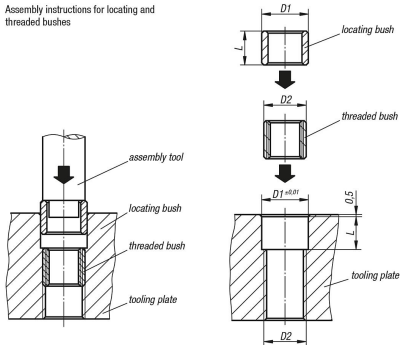

Assembly instructions for locating and threaded bushes



Description

Material:
Carbon steel.

Version:
Tempered to 1100-1300 N/mm².

Note:
Assembly instructions for changing threaded bushing.

Inserting the locating and threaded bushing

1. Remove grease from the locating and threaded bushing.
2. Apply adhesive (Loctite 638) in the hole.
3. Apply adhesive (Loctite 638) on the threaded bushing and screw in.
4. Apply adhesive (Loctite 638) to the locating bushing and insert it. If the locating bushing cannot be inserted by hand, please use an assembly tool as shown application example:.
5. Remove any adhesive pressed out by insertion of the locating and threaded bushing before it hardens.

Drawings

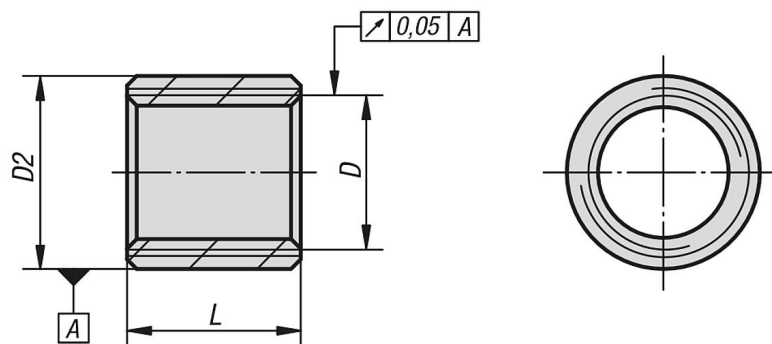

Overview of items

Threaded bushings for grid systems

Order No.	D	D2	L
K0863.01508305003	M8	M12x1,75	12
K0863.01012304003	M12	M16x1,5	15
K0863.01016405003	M16	M20x1,5	18