

Indexing plungers, steel or stainless steel, short version with plastic mushroom grip, locking slot and locknut

Item description/product images



Description

Material:

Steel version

Indexing pin hardened:
grade 5.8

Stainless steel version

Indexing pin not hardened:
Threaded sleeve 1.4305.
Indexing pin 1.4305.

Mushroom grip thermoplastic, black-grey or traffic red RAL 3020.

Version:

Steel version:

Indexing pin hardened, ground, black oxidised.

Stainless steel version:

Indexing pin not hardened, ground, bright.

Note:

Indexing plungers are used to prevent any change in position due to lateral forces. A new locking position can only be set after the pin has been manually disengaged. Form C or D is recommended for applications in which the pin is disengaged over extended periods and should be prevented from springing back.

On request:

Special versions.

Indexing plungers, steel or stainless steel, short version with plastic mushroom grip, locking slot and locknut

Drawings

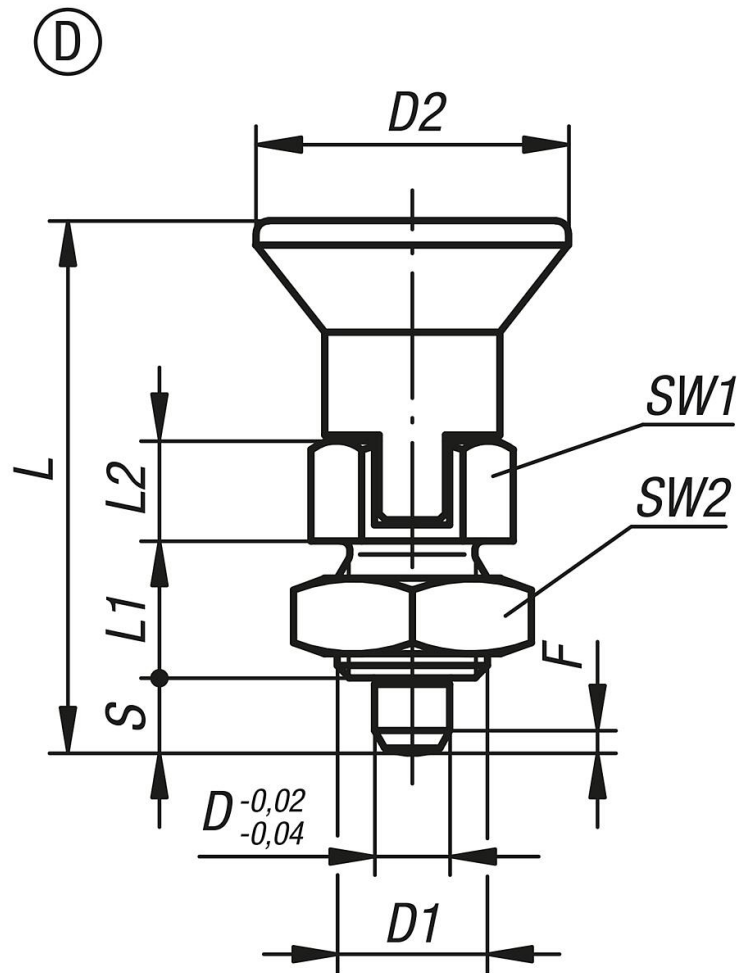

Overview of items

Order No.	Form	Main material	Surface finish body	Component colour	D	D1	D2	L	L1	L2	Travel S	SW1	SW2	Fx30°	Spring force initial pressure F1 approx. N	Spring force final pressure F2 approx. N
K0631.8903	D	steel	hardened	black grey RAL 7021	3	M6x0,75	14	25,5	6	5	3,5	8	10	0,8	4	10
K0631.8004	D	steel	hardened	black grey RAL 7021	4	M8x1	18	29,5	6	6	4	10	13	1	4	12
K0631.8105	D	steel	hardened	black grey RAL 7021	5	M10x1	21	34,5	8	7	5	13	17	1,3	5	12
K0631.8206	D	steel	hardened	black grey RAL 7021	6	M12x1,5	25	41,7	10	8	6	14	19	1,8	6	14
K0631.8308	D	steel	hardened	black grey RAL 7021	8	M16x1,5	33	54	12	10	8	19	24	2,3	14	28
K0631.8410	D	steel	hardened	black grey RAL 7021	10	M20x1,5	33	61	15	12	10	22	30	2,8	15	32
K0631.890384	D	steel	hardened	traffic red RAL 3020	3	M6x0,75	14	25,5	6	5	3,5	8	10	0,8	4	10
K0631.800484	D	steel	hardened	traffic red RAL 3020	4	M8x1	18	29,5	6	6	4	10	13	1	4	12
K0631.810584	D	steel	hardened	traffic red RAL 3020	5	M10x1	21	34,5	8	7	5	13	17	1,3	5	12
K0631.820684	D	steel	hardened	traffic red RAL 3020	6	M12x1,5	25	41,7	10	8	6	14	19	1,8	6	14
K0631.830884	D	steel	hardened	traffic red RAL 3020	8	M16x1,5	33	54	12	10	8	19	24	2,3	14	28
K0631.841084	D	steel	hardened	traffic red RAL 3020	10	M20x1,5	33	61	15	12	10	22	30	2,8	15	32
K0631.18903	D	stainless steel	not hardened	black grey RAL 7021	3	M6x0,75	14	25,5	6	5	3,5	8	10	0,8	4	10
K0631.18004	D	stainless steel	not hardened	black grey RAL 7021	4	M8x1	18	29,5	6	6	4	10	13	1	4	12
K0631.18105	D	stainless steel	not hardened	black grey RAL 7021	5	M10x1	21	34,5	8	7	5	13	17	1,3	5	12
K0631.18206	D	stainless steel	not hardened	black grey RAL 7021	6	M12x1,5	25	41,7	10	8	6	14	19	1,8	6	14
K0631.18308	D	stainless steel	not hardened	black grey RAL 7021	8	M16x1,5	33	54	12	10	8	19	24	2,3	14	28
K0631.18410	D	stainless steel	not hardened	black grey RAL 7021	10	M20x1,5	33	61	15	12	10	22	30	2,8	15	32
K0631.1890384	D	stainless steel	not hardened	traffic red RAL 3020	3	M6x0,75	14	25,5	6	5	3,5	8	10	0,8	4	10
K0631.1800484	D	stainless steel	not hardened	traffic red RAL 3020	4	M8x1	18	29,5	6	6	4	10	13	1	4	12
K0631.1810584	D	stainless steel	not hardened	traffic red RAL 3020	5	M10x1	21	34,5	8	7	5	13	17	1,3	5	12
K0631.1820684	D	stainless steel	not hardened	traffic red RAL 3020	6	M12x1,5	25	41,7	10	8	6	14	19	1,8	6	14

Indexing plungers, steel or stainless steel, short version with plastic mushroom grip, locking slot and locknut

Overview of items

Order No.	Form	Main material	Surface finish body	Component colour	D	D1	D2	L	L1	L2	Travel S	SW1	SW2	Fx30°	Spring force initial pressure F1 approx. N	Spring force final pressure F2 approx. N
K0631.1830884	D	stainless steel	not hardened	traffic red RAL 3020	8	M16x1,5	33	54	12	10	8	19	24	2,3	14	28
K0631.1841084	D	stainless steel	not hardened	traffic red RAL 3020	10	M20x1,5	33	61	15	12	10	22	30	2,8	15	32