

Hinges steel or stainless steel internal, opening angle 125°

Item description/product images

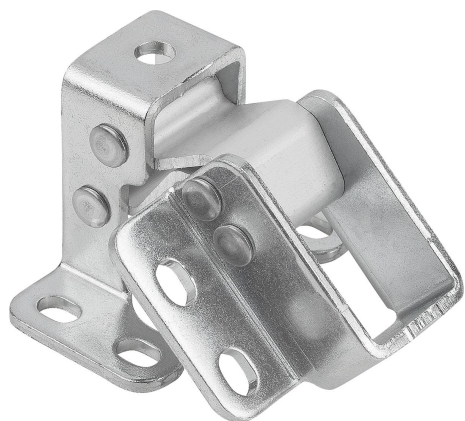
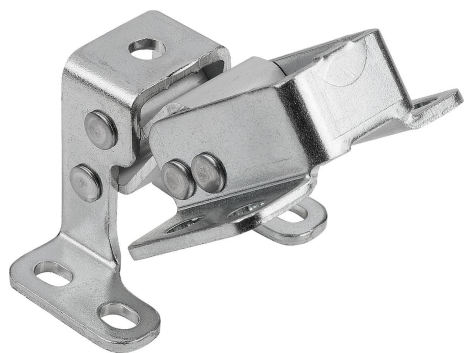
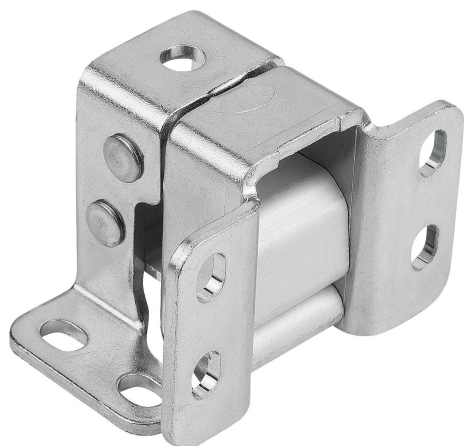

Description

Material:

Steel, axis and connecting elements anodised aluminium.

Stainless steel 1.4404, axis and connecting elements anodised aluminium.

Version:

Electro zinc-plated.

Bright.

Note:

The hinges are resistant to bending and torsion.

The opening angle depends on the door thickness:

- max. 2 mm material thickness: opening angle 125°
- max. 8 mm material thickness: opening angle 110°
- max. 13 mm material thickness: opening angle 100°

Assembly:

- For recessed or surface mounting.
- Can be mounted on right or left side.
- For horizontal or vertical applications.

Drawing reference:

1) recessed mounting

2) surface mounting

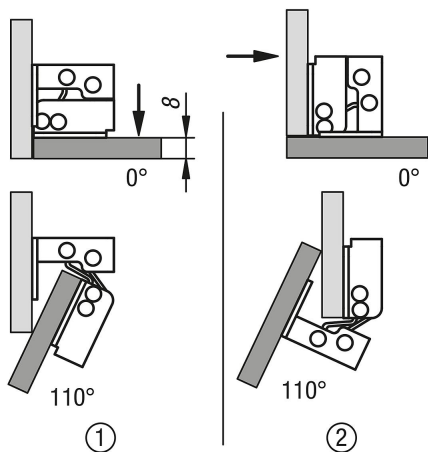

Hinges steel or stainless steel internal, opening angle 125°

Item description/product images

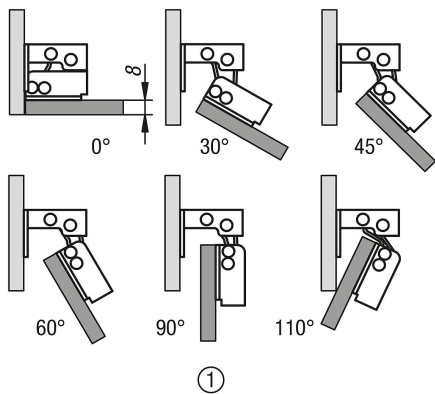

Drawings

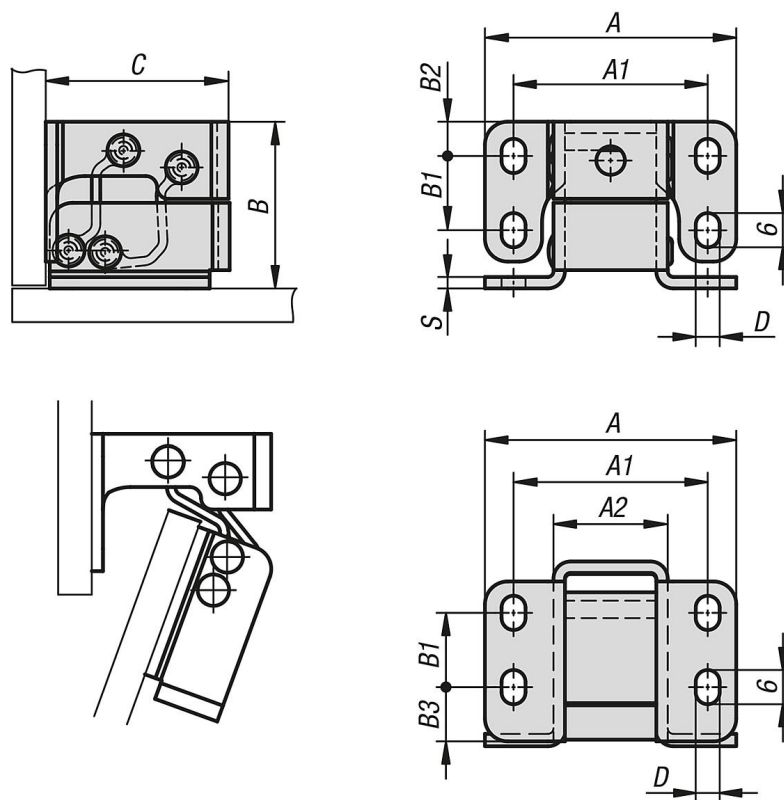

Overview of items

Hinges steel or stainless steel, internal, opening angle 125°

Order No.	Main material	A	A1	A2	B	B1	B2	B3	C	D	S
K1448.442932	steel	44	34	20	29	13	6	9,5	32	4,2	2
K1448.1442932	stainless steel A4	44	34	20	29	13	6	9,5	32	4,2	2

