

Clamp straps pivot strap only or assembly

Item description/product images



Description

Material:
Steel.

Version:
Forged, tempered and painted.
Bolts, nuts, washers grade 8.8

Note:
The strap provides instant height adjustment without blocks or shims and requires little space on the machine table. Designed for rugged use and highly suitable for clamping blanking and punching dies.

Drawings

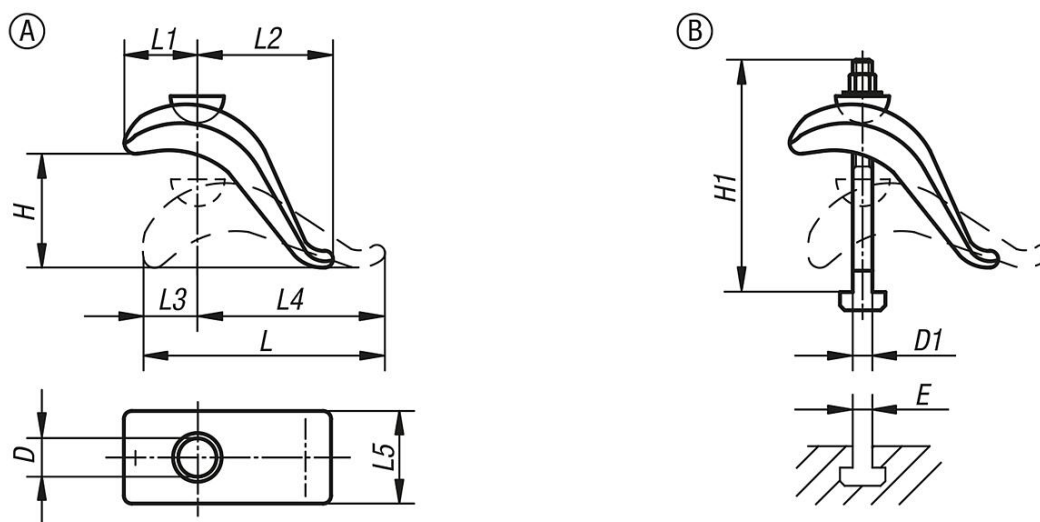

Overview of items

Form A strap only

Order No.	Form	D	H	L	L1	L2	L3	L4	L5	Clamping force kN
K1954.010	A	17	75	140	55	60	30	110	50	20,2
K1954.020	A	21	85	175	70	80	40	135	60	37,8

Form B with T-slot bolt, nut and washer

Order No.	Form	D	D1	E	H	H1	L	L1	L2	L3	L4	L5	Clamping force kN
K1954.030	B	17	M12	12	50	125	140	50	80	30	110	50	20,2
K1954.040	B	17	M12	14	50	125	140	50	80	30	110	50	20,2
K1954.050	B	17	M16	16	75	160	140	55	60	30	110	50	37,8
K1954.060	B	17	M16	18	75	160	140	55	60	30	110	50	37,8

Clamp straps pivot strap only or assembly

Overview of items

Order No.	Form	D	D1	E	H	H1	L	L1	L2	L3	L4	L5	Clamping force kN
K1954.080	B	21	M16	16	65	160	175	70	95	40	135	60	37,8
K1954.100	B	21	M16	18	65	160	175	70	95	40	135	60	37,8
K1954.120	B	21	M20	22	85	200	175	70	80	40	135	60	58,8