

Screw rest with flat face, steel

Item description/product images



Description

Material:

Carbon steel.

Version:

Painted, trapezoidal thread - self-locking, spindle has end lock

Note:

The version K1941-01 has no $\varnothing 12$ centring hole.

Drawing reference:

1) centring hole for K1961

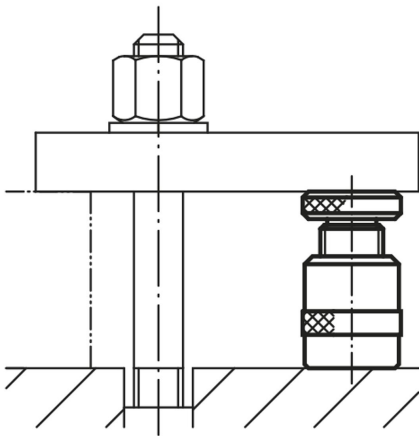

Screw rest with flat face, steel

Drawings

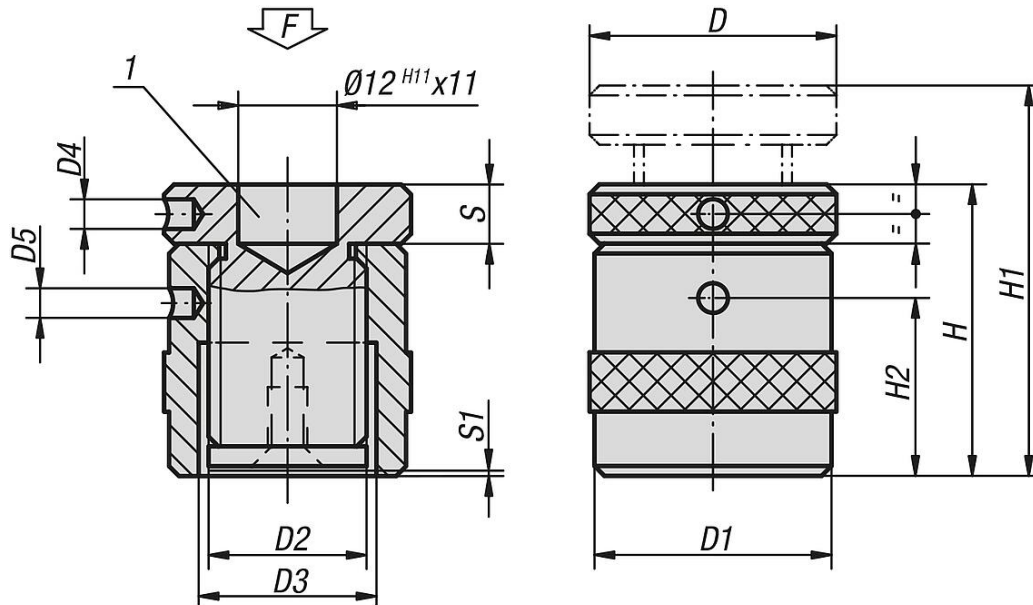

Overview of items

Screw rests with flat support face, steel

Order No.	D	D1	D2	D3	D4	D5	H	H1	H2	S	S1	F max. kN
K1941.01	31	31	Tr 20X4	23	4	4	38	52	23	8	2	15
K1941.015	50	49	Tr 30X4	36	6	6	42	52	24	12	2	60
K1941.02	50	49	Tr 30X4	36	6	6	50	72	30	12	0,5	60
K1941.03	50	49	Tr 30X4	36	6	6	71	102	43	16	1,5	60
K1941.04	65	70	Tr 40X7	43	6	6	100	140	58	25	2,5	100
K1941.05	70	80	Tr 50X8	55	6	6	140	212	90	30	4	170
K1941.06	80	100	Tr 65X10	70	6	8	190	300	126	34	5	350