

Fixture feet with internal thread, Form A hardened flat face

Item description/product images



Description

Material:

Body high carbon steel.

Version:

Body tempered and black oxidised.

Contact faces case-hardened.

Note:

Fixture feet with internal thread are used as supports for fixtures or rough or machined workpieces. They can also be used as stops or thrust pads in fixtures and toolmaking.

Drawings

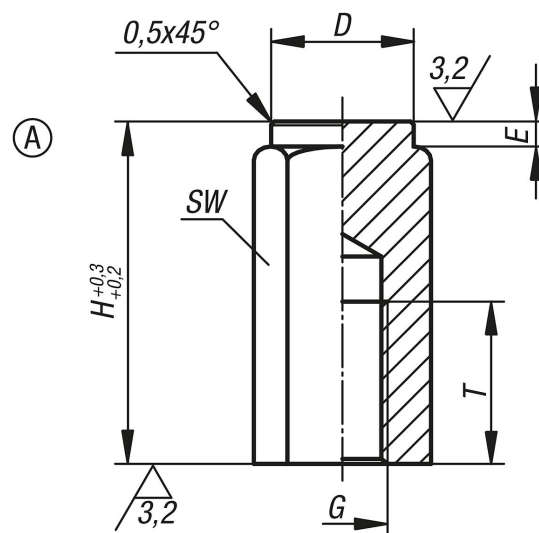

Overview of items

Order No.	Form	D	E	G	H	T	SW
K0301.106X20	A	9,5	2	M6	20	12	10
K0301.106X40	A	9,5	2	M6	40	12	10
K0301.110X32	A	16,5	3	M10	32	18	17
K0301.110X63	A	16,5	3	M10	63	18	17
K0301.112X32	A	18,5	3	M12	32	18	19
K0301.112X63	A	18,5	3	M12	63	18	19
K0301.116X50	A	23	4	M16	50	24	24
K0301.116X100	A	23	4	M16	100	24	24

