

Magnets deep pot SmCo, Form A

Item description/product images



Description

Material:

Housing brass.

Magnetic core SmCo.

Note:

Smooth design, shielded system. Diameter "D" ground with h6 tolerance. Under no circumstances may SmCo magnets be pressed directly into iron, loss of attractive force due to magnetic short circuits occurs. SmCo magnets are especially suitable for direct use in spot-welding machines, as no demagnetisation occurs.

Deep pot magnets can be shortened by the dimension "H1" with no loss of magnetic force.

Temperature range:

max. 200°C.

Drawing reference:

1) magnetic face

Drawings

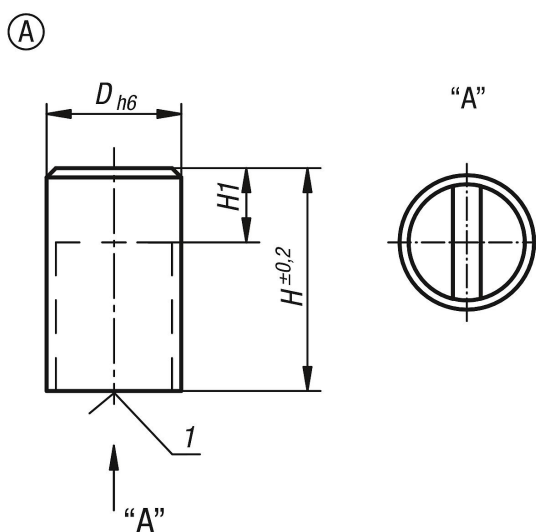

Overview of items

Order No.	Form	D	H	H1	Magnetic force N	Distance to iron wall/mm
K0551.01	A	6	20	10	8	1,5
K0551.03	A	8	20	10	22	1,5
K0551.05	A	10	20	8	40	2
K0551.07	A	13	20	6	60	2,5
K0551.09	A	16	20	2	125	3
K0551.11	A	20	25	5	250	4
K0551.13	A	25	35	7	400	5
K0551.15	A	32	40	4,5	600	6

