

Mini tooling blocks, grey cast iron with pre-machined clamping faces

Item description/product images



Description

Material:
GJL 300.

Version:
Support and mounting surfaces ground

Note:
Tooling blocks with pre-machined clamping faces are used for constructing fixtures. These tooling blocks provide a fast and economic method of producing bodies with specific grid or individual holes. Tooling blocks can also be used as a body for clamping smaller workpieces.

Drawings

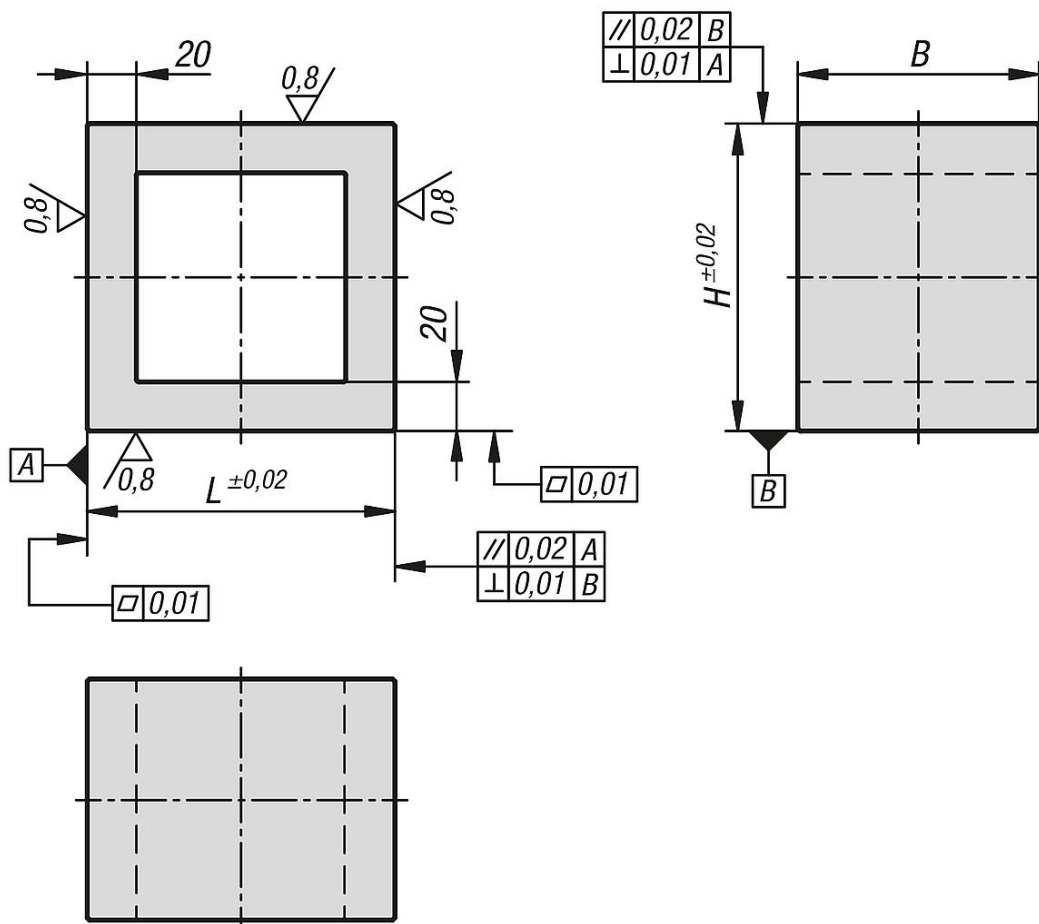

Overview of items

Mini tooling blocks, grey cast iron with pre-machined clamping faces

Mini tooling blocks, grey cast iron with pre-machined clamping faces**Overview of items**

Order No.	L	B	H
K0809.10012598125	125	98	125