

## Ratchet levers

### Item description/product images

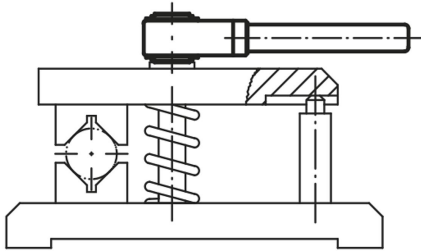

### Description

**Material:**

Housing carbon steel, tension nut and tension pin case-hardened steel.

**Version:**

Black oxidised.

Matt-finished or high-polish chrome-plated versions available at extra charge.

**Note:**

Tension Pin A standard version (for ratchet action):

Use for clamping and releasing in limited space and when considerable travel is involved. In order to change the tightening direction, the handle must be reversed by 180°.

Tension Pin B special version:

Use for clamping and releasing in limited space and when short travel is involved.

The handle is not reversed in order to change the tightening direction. It must be pulled out before it can be engaged in the next slot.

Clamp with H7 reamed hole and DIN 6885/1 keyway.

**On request:**

Other thread, reamed hole and square socket sizes.

Dimension "A" available in other lengths at extra charge.

Special version: Tension pin B.

## Ratchet levers

### Drawings

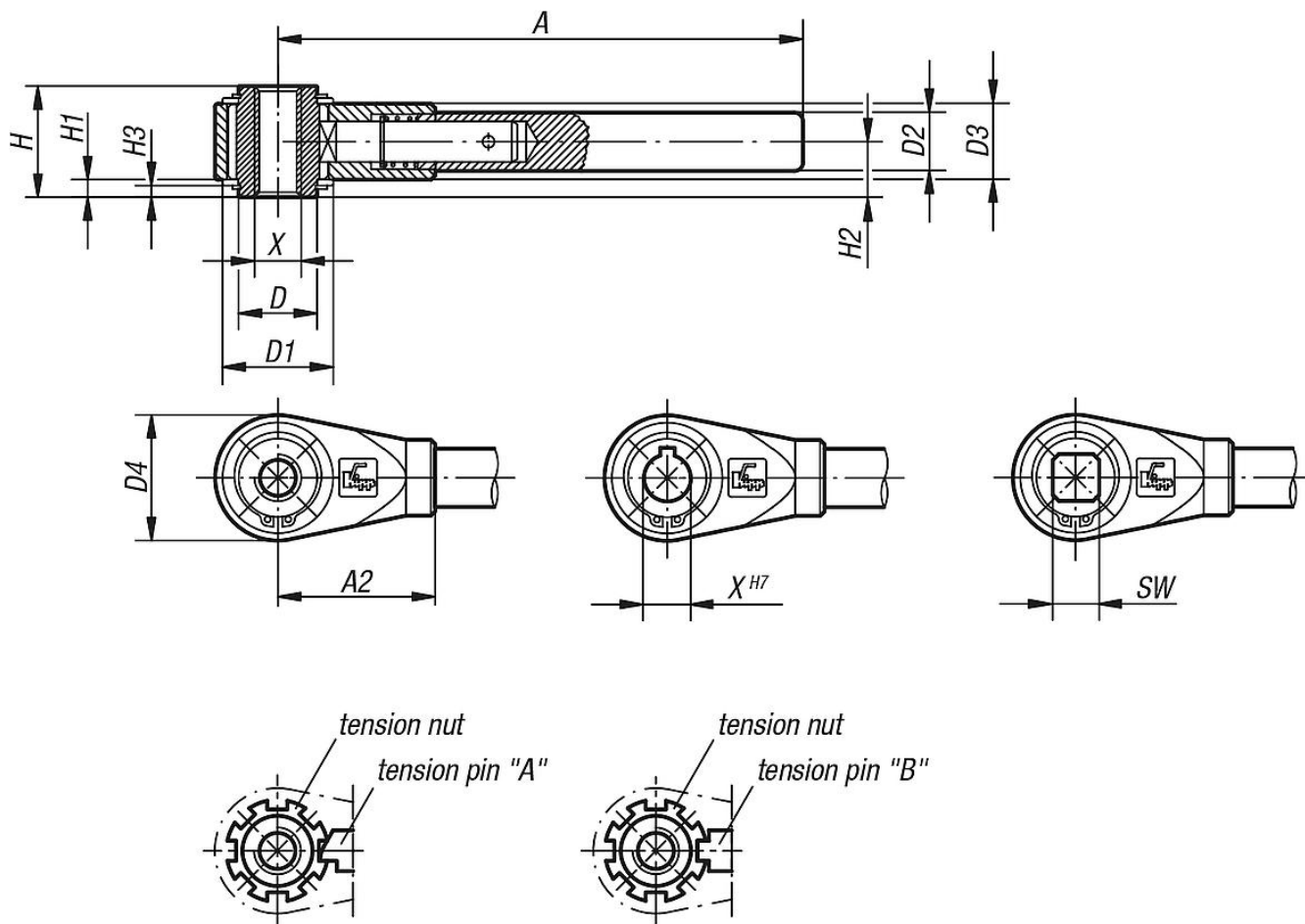

### Overview of items

#### Ratchet levers with female thread

Order No.	Kind of fastening	X	A=Handle length	A2	D	D1	D2	D3	D4	H	H1	H2	H3	SW	No. of index slots
K0128.310	internal thread	M10	150	48	22	33	17	22	36	31	4,5	15,5	3	-	7
K0128.312	internal thread	M12	150	48	22	33	17	22	36	31	4,5	15,5	3	-	7
K0128.314	internal thread	M14	180	54	27	38	20	26	43	38	6	19	4	-	8
K0128.316	internal thread	M16	180	54	27	38	20	26	43	38	6	19	4	-	8
K0128.318	internal thread	M18	230	70	35	45	24	30	51	42	6	21	4	-	8
K0128.320	internal thread	M20	230	70	35	45	24	30	51	42	6	21	4	-	8
K0128.322	internal thread	M22	300	80	42	56	28	35	61	47	6	23,5	4	-	9
K0128.324	internal thread	M24	300	80	42	56	28	35	61	47	6	23,5	4	-	9
K0128.327	internal thread	M27	300	80	42	56	28	35	61	47	6	23,5	4	-	9
K0128.330	internal thread	M30	400	110	60	75	32	38	82	53	7,5	26,5	5	-	11
K0128.336	internal thread	M36	400	110	60	75	32	38	82	53	7,5	26,5	5	-	11
K0128.342	internal thread	M42	400	110	60	75	32	38	82	53	7,5	26,5	5	-	11
K0128.412	reamed hole with slot	12	150	48	22	33	17	22	36	31	4,5	15,5	3	-	7
K0128.414	reamed hole with slot	14	180	54	27	38	20	26	43	38	6	19	4	-	8
K0128.415	reamed hole with slot	15	180	54	27	38	20	26	43	38	6	19	4	-	8
K0128.416	reamed hole with slot	16	180	54	27	38	20	26	43	38	6	19	4	-	8
K0128.418	reamed hole with slot	18	230	70	35	45	24	30	51	42	6	21	4	-	8
K0128.420	reamed hole with slot	20	230	70	35	45	24	30	51	42	6	21	4	-	8
K0128.422	reamed hole with slot	22	300	80	42	56	28	35	61	47	6	23,5	4	-	9
K0128.425	reamed hole with slot	25	300	80	42	56	28	35	61	47	6	23,5	4	-	9
K0128.427	reamed hole with slot	27	300	80	42	56	28	35	61	47	6	23,5	4	-	9

## Ratchet levers

### Overview of items

Order No.	Kind of fastening	X	A=Handle length	A2	D	D1	D2	D3	D4	H	H1	H2	H3	SW	No. of index slots
K0128.430	reamed hole with slot	30	400	110	60	75	32	38	82	53	7,5	26,5	5	-	11
K0128.436	reamed hole with slot	36	400	110	60	75	32	38	82	53	7,5	26,5	5	-	11
K0128.510	square socket	-	150	48	22	33	17	22	36	31	4,5	15,5	3	10	7
K0128.512	square socket	-	150	48	22	33	17	22	36	31	4,5	15,5	3	12	7
K0128.513	square socket	-	180	54	27	38	20	26	43	38	6	19	4	13	8
K0128.514	square socket	-	180	54	27	38	20	26	43	38	6	19	4	14	8
K0128.517	square socket	-	230	70	35	45	24	30	51	42	6	21	4	17	8
K0128.519	square socket	-	300	80	42	56	28	35	61	47	6	23,5	4	19	9
K0128.520	square socket	-	300	80	42	56	28	35	61	47	6	23,5	4	20	9
K0128.522	square socket	-	300	80	42	56	28	35	61	47	6	23,5	4	22	9
K0128.524	square socket	-	300	80	42	56	28	35	61	47	6	23,5	4	24	9
K0128.530	square socket	-	400	110	60	75	32	38	82	53	7,5	26,5	5	30	11
K0128.532	square socket	-	400	110	60	75	32	38	82	53	7,5	26,5	5	32	11