

Ball lock pins with stainless steel mushroom grip and high shear strength

Item description/product images

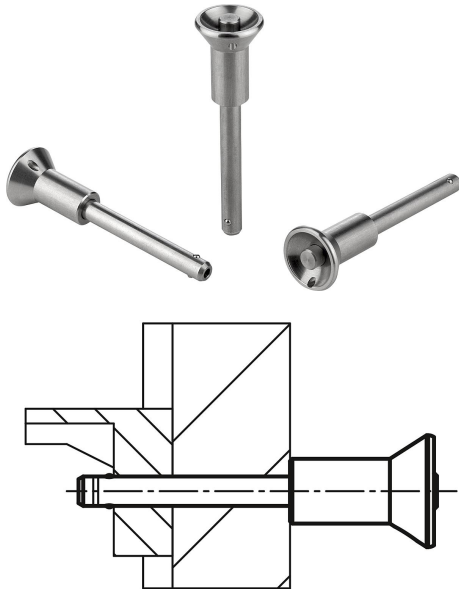

Description

Material:

Mushroom knob and push button stainless steel 1.4305.

Pin stainless steel 1.4542.

Balls stainless steel 1.4125.

Compression spring stainless steel 1.4310.

Version:

Bright.

Note:

Ball lock pins are used for easy fastening or joining of components.

The two balls are disengaged by pressing the push button and the pin can be slipped into holes in the workpieces. When the push button is released, the balls lock the connection securely.

Shear force double shear (F) = S · τ aB max.

The values given for the shear force are the theoretical breaking load.

These are non-binding reference values without consideration of safety factors and exclude any liability. The values given are for information purposes only and do not constitute a legally binding assurance of properties.

The load values have been calculated in accordance with DIN 50141. Each user must determine individually whether the ball lock pin is suitable for the respective application.

Different materials in which the ball lock pins are used, weather conditions and wear can influence the determined values.

Ball lock pins with high shear strength are identified by a groove marking on the pin.

Advantages:

Higher loading in comparison to standard ball lock pins.

The pins made from 1.4542 stainless steel is hardened, has a higher shear resistance and is extremely durable.

Accessory:

Bushes for ball lock pins K0724

Safety spiral cable K0367

Retaining cable with loop K0367

Key ring K0367

Ball lock pins with stainless steel mushroom grip and high shear strength

Drawings

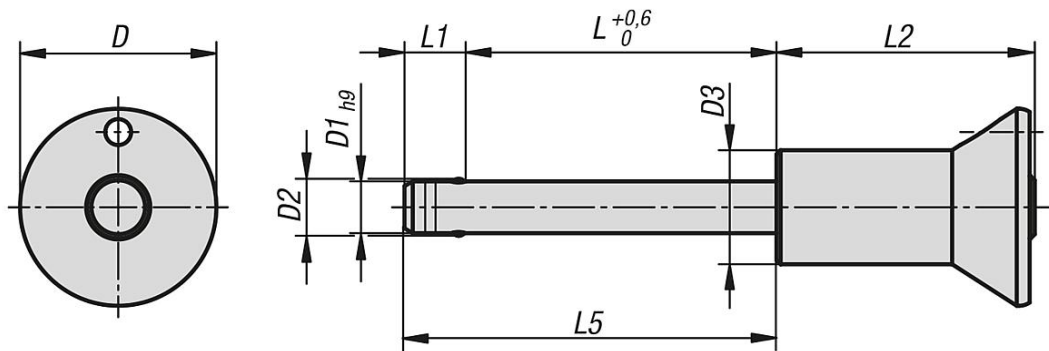

Overview of items

Ball lock pins with mushroom grip, stainless steel, with high shear strength

Order No.	D	D1	D2	D3	L	L1	L2	L5	Receiving hole H11	Shearing force double shear max.kN
K0791.11905010	19	5	5,5	11	10	5,9	25	15,9	5	24
K0791.11905015	19	5	5,5	11	15	5,9	25	20,9	5	24
K0791.11905020	19	5	5,5	11	20	5,9	25	25,9	5	24
K0791.11905025	19	5	5,5	11	25	5,9	25	30,9	5	24
K0791.11905030	19	5	5,5	11	30	5,9	25	35,9	5	24
K0791.11906010	19	6	6,85	11	10	6,8	25	16,8	6	35
K0791.11906015	19	6	6,85	11	15	6,8	25	21,8	6	35
K0791.11906020	19	6	6,85	11	20	6,8	25	26,8	6	35
K0791.11906025	19	6	6,85	11	25	6,8	25	31,8	6	35
K0791.11906030	19	6	6,85	11	30	6,8	25	36,8	6	35
K0791.11906035	19	6	6,85	11	35	6,8	25	41,8	6	35
K0791.11906040	19	6	6,85	11	40	6,8	25	46,8	6	35
K0791.11906045	19	6	6,85	11	45	6,8	25	51,8	6	35
K0791.11906050	19	6	6,85	11	50	6,8	25	56,8	6	35
K0791.12508020	25	8	9,5	14	20	7,8	33	27,8	8	63
K0791.12508025	25	8	9,5	14	25	7,8	33	32,8	8	63
K0791.12508030	25	8	9,5	14	30	7,8	33	37,8	8	63
K0791.12508035	25	8	9,5	14	35	7,8	33	42,8	8	63
K0791.12508040	25	8	9,5	14	40	7,8	33	47,8	8	63
K0791.12508045	25	8	9,5	14	45	7,8	33	52,8	8	63
K0791.12508050	25	8	9,5	14	50	7,8	33	57,8	8	63
K0791.12510020	25	10	12	14	20	8,9	33	28,9	10	100
K0791.12510025	25	10	12	14	25	8,9	33	33,9	10	100
K0791.12510030	25	10	12	14	30	8,9	33	38,9	10	100
K0791.12510035	25	10	12	14	35	8,9	33	43,9	10	100
K0791.12510040	25	10	12	14	40	8,9	33	48,9	10	100
K0791.12510045	25	10	12	14	45	8,9	33	53,9	10	100
K0791.12510050	25	10	12	14	50	8,9	33	58,9	10	100
K0791.12510060	25	10	12	14	60	8,9	33	68,9	10	100
K0791.13512025	35	12	14,5	22	25	9,9	39,5	34,9	12	144
K0791.13512030	35	12	14,5	22	30	9,9	39,5	39,9	12	144
K0791.13512035	35	12	14,5	22	35	9,9	39,5	44,9	12	144
K0791.13512040	35	12	14,5	22	40	9,9	39,5	49,9	12	144
K0791.13512045	35	12	14,5	22	45	9,9	39,5	54,9	12	144
K0791.13512050	35	12	14,5	22	50	9,9	39,5	59,9	12	144
K0791.13512060	35	12	14,5	22	60	9,9	39,5	69,9	12	144
K0791.13512070	35	12	14,5	22	70	9,9	39,5	79,9	12	144
K0791.13512080	35	12	14,5	22	80	9,9	39,5	89,9	12	144
K0791.13516030	35	16	19	22	30	13,1	39,5	43,1	16	257
K0791.13516035	35	16	19	22	35	13,1	39,5	48,1	16	257
K0791.13516040	35	16	19	22	40	13,1	39,5	53,1	16	257

Ball lock pins with stainless steel mushroom grip and high shear strength

Overview of items

Order No.	D	D1	D2	D3	L	L1	L2	L5	Receiving hole H11	Shearing force double shear max.kN
K0791.13516045	35	16	19	22	45	13,1	39,5	58,1	16	257
K0791.13516050	35	16	19	22	50	13,1	39,5	63,1	16	257
K0791.13516060	35	16	19	22	60	13,1	39,5	73,1	16	257
K0791.13516070	35	16	19	22	70	13,1	39,5	83,1	16	257
K0791.13516080	35	16	19	22	80	13,1	39,5	93,1	16	257