

Modular structure of a swivel pad

Application:

Swivel pads are built up in modular fashion. The components can be combined individually to match the application. The swivel pads are therefore used for a wide range of machines and installations, including office furniture.

Modular structure:

The swivel pads consist of two components - a plate and a threaded spindle resp. a ball joint. **Any** plate can be combined with **any** threaded spindle resp. **any** ball joint (see figure 1).

Height of swivel pad:

Swivel pads always have a minimum height of $H = 22,5$ mm independently of the plate or threaded spindle or ball joint size (see figure 2). When assembling with threaded spindle, the height of the complete swivel pad is calculated by adding 22,5 mm to the length of the threaded spindle, and the height of the hexagon. (Total height swivel pad = $L + L1 + 22,5$ mm)

When assembling with ball joint, the length L is void.

Figure 1

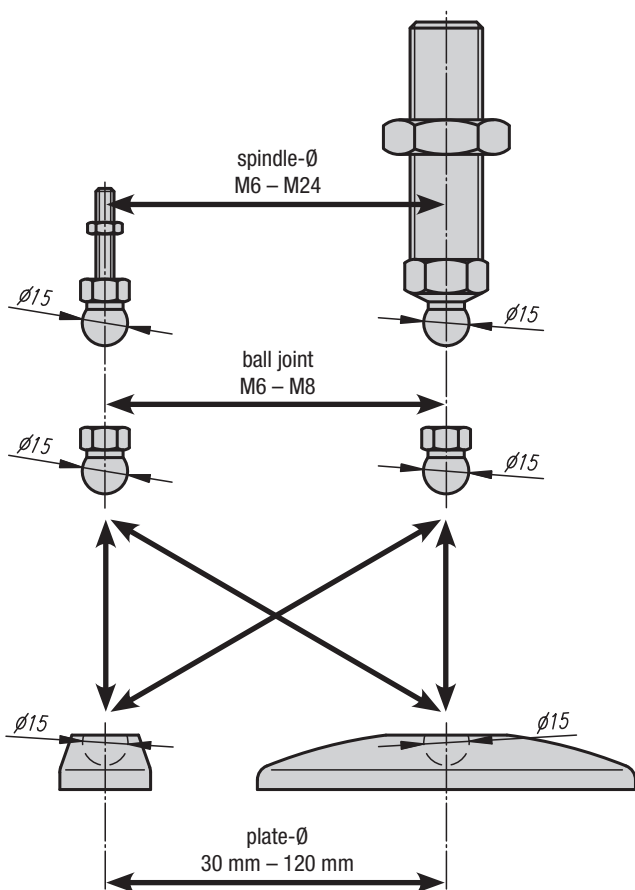

Assembly:

Using a plastic hammer, knock the ball of the threaded spindle resp. the ball joint vertically into the swivel pad plate. If necessary, the two fastening holes (closed) in the swivel pad plate can be opened by simply punching them out to allow the swivel pad to be mounted to the ground.

Figure 2

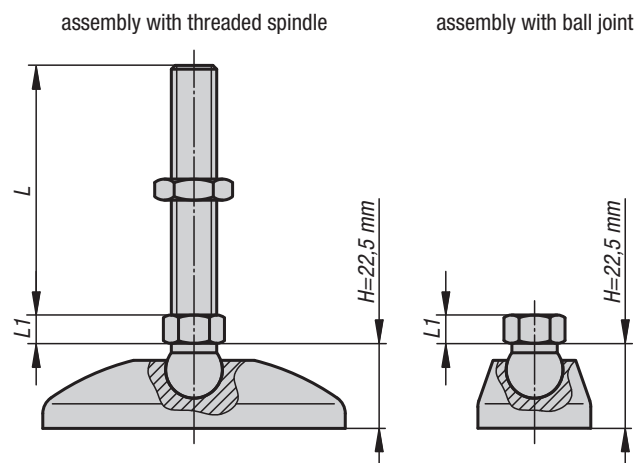

Inclination angle of threaded spindle resp. ball joint:

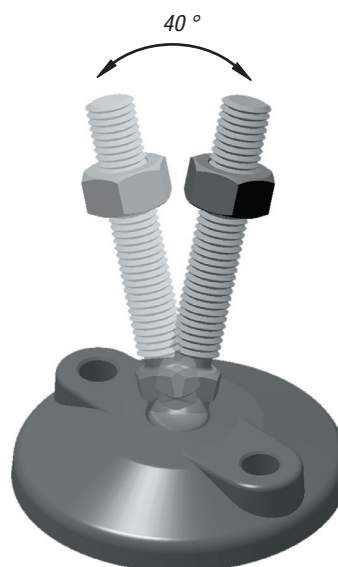

Note for ordering:

If the swivel pad plate and the threaded spindle resp. the ball joint are to be supplied assembled, please add the suffix „**assembled**“ to the order number for the plate and the spindle resp. the ball joint (see sample order on the relevant product page).