

Handles screw-in with torque limit

Item description/product images



Description

Material:
Carbon steel.

Version:
Hardened, black oxidised.

Note:
The desired clamping force can be set by using the set screw to alter the torque. The handle snaps 15° when the set torque is achieved.

Note:
Ensure that the handle is set to snap horizontally.

Drawings

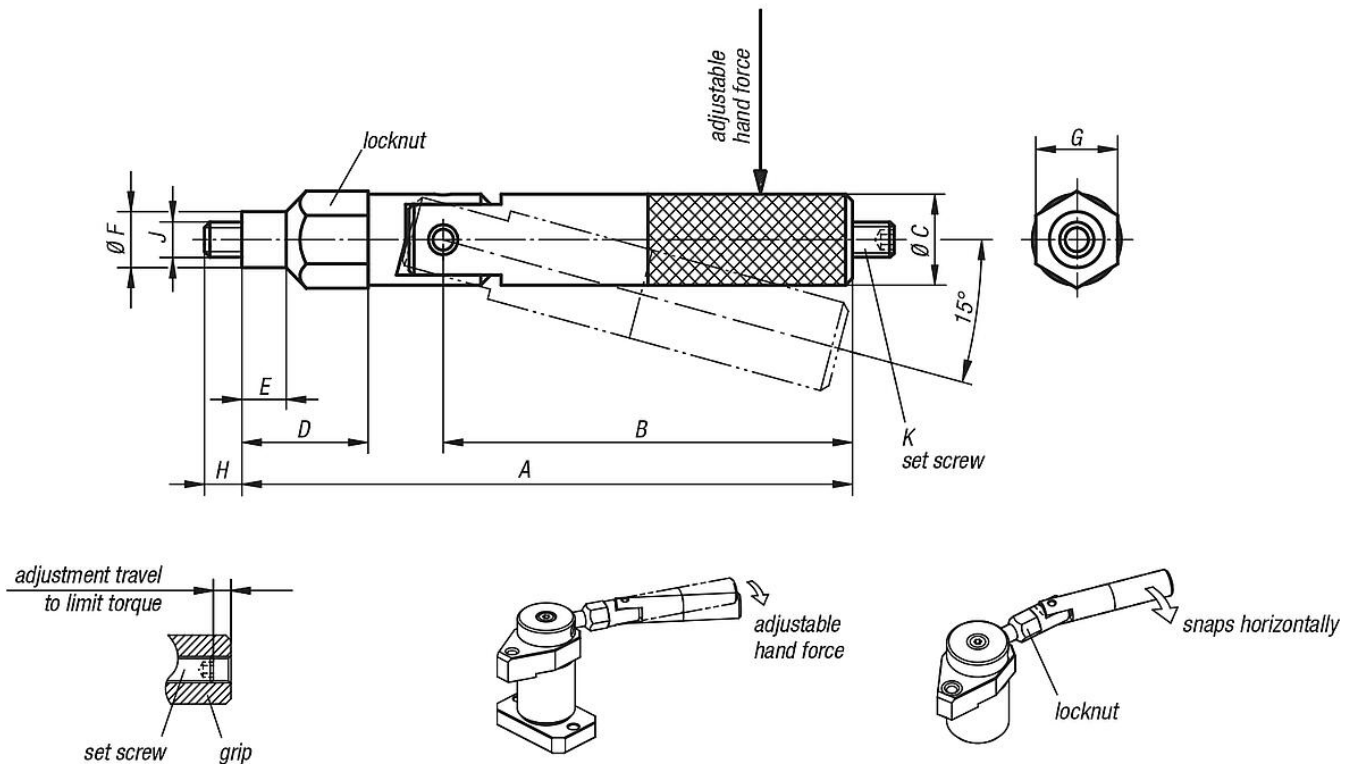

Handles screw-in with torque limit

Drawings

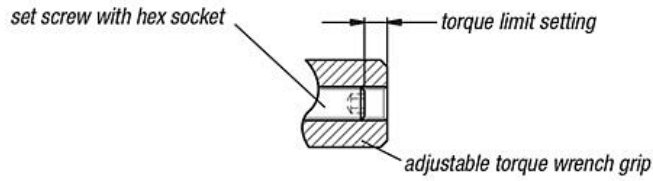

Pull Clamps K0910.3240...

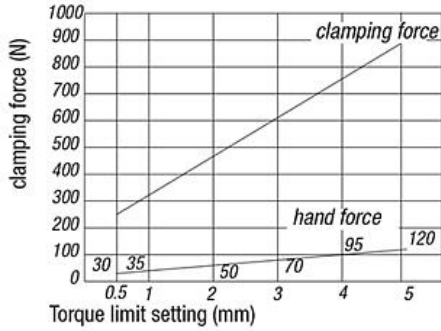

If clamping force is 900 N, Load-Setting Distance will be 5 mm. Hand force will be 120 N.

Pull Clamps K0910.4050...

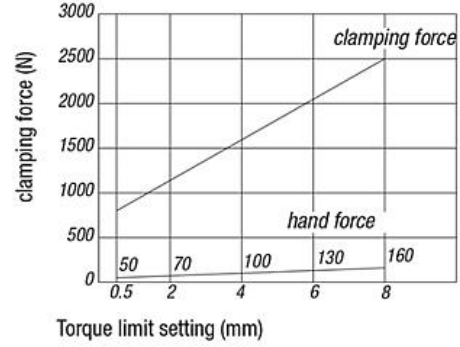

Swing Clamps K0912....3232

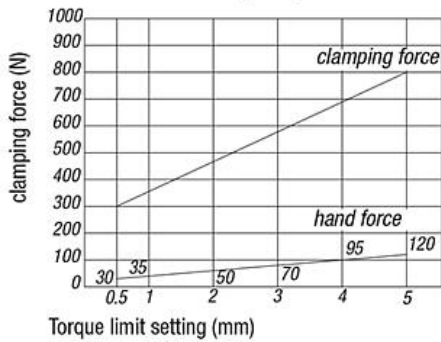

Swing Clamps K0912....4540

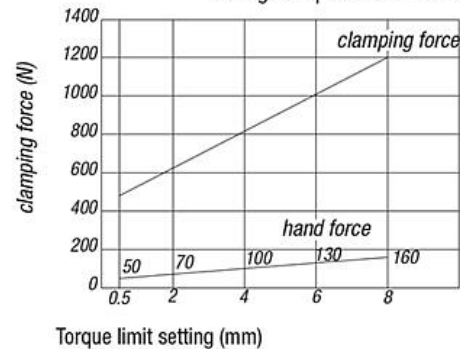

Side Clamps K0928.0500
K0928.0501

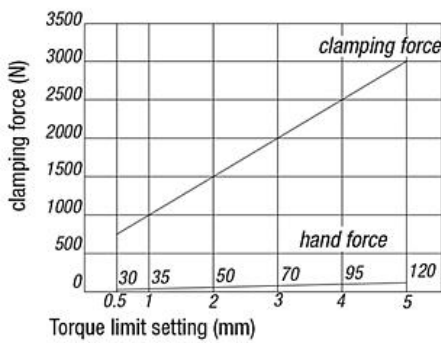

Side Clamps K0928.0800
K0928.0801

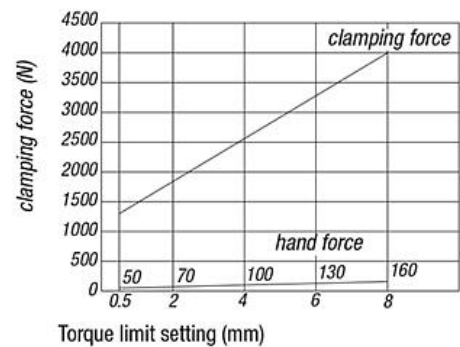

Note:
The above performance curves apply to degreased clamps

Handles screw-in with torque limit

Overview of items

Handles, screw-in, with torque limit

Order No.	A	B	C	D	E	F	G	H	J	K	Hand force FH N
K0916.05090	89,5	60	13	18,5	6,5	8	12	5,5	M5	M5x16	0-150
K0916.06119	119	84	15	23	8	10	14	6,5	M6	M6x20	0-200