

## Spring plungers with slot and ball, stainless steel, with thread lock

Item description/product images



KIPPlack



### Description

**Material:**

Sleeve 1.4305.

Ball 1.4034.

Spring 1.4310.

Thread lock nylon.

**Version:**

Bright. Ball hardened.

**Drawing reference:**

L2 = approx. 2x thread pitch

Spring plungers with slot and ball, stainless steel, with thread lock

Drawings

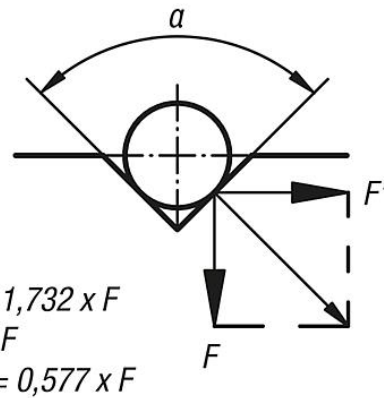
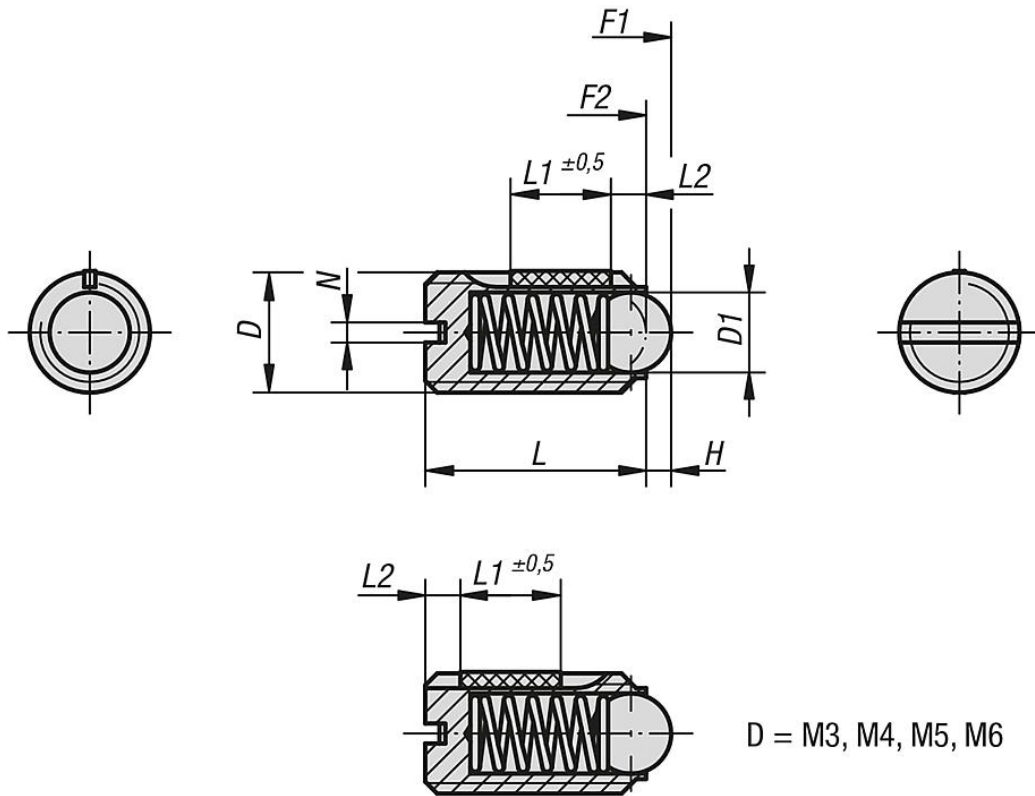

Overview of items

Spring plungers with slot and ball, stainless steel, with thread lock

Order No.	D	D1	H	L	L1	N	Spring force initial pressure F1 approx. N	Spring force final pressure F2 approx. N	Tightening torque approx. Nm	Loosening torque approx. Nm
K0322.03	M3	1,5	0,4	7	4	0,4	1,5	3	0,1	0,07
K0322.04	M4	2,5	0,8	9	5	0,6	4	10	0,18	0,12
K0322.05	M5	3	0,9	12	6	0,8	6	11	0,12	0,08
K0322.06	M6	3,5	1	14	7	1	9	13	0,43	0,21
K0322.08	M8	5	1,5	16	8	1,2	15	30	1,09	0,37
K0322.10	M10	6	2	19	9	1,6	20	35	1,36	0,62

## Spring plungers with slot and ball, stainless steel, with thread lock

### Overview of items

Order No.	D	D1	H	L	L1	N	Spring force initial pressure F1 approx. N	Spring force final pressure F2 approx. N	Tightening torque approx. Nm	Loosening torque approx. Nm
<b>K0322.12</b>	M12	8	2,5	22	10	2	30	55	2,03	1,36
<b>K0322.16</b>	M16	10	3,5	24	14	2,5	65	125	3,95	2,95
<b>K0322.203</b>	M3	1,5	0,4	7	4	0,4	5	7	0,1	0,07
<b>K0322.204</b>	M4	2,5	0,8	9	5	0,6	12	22	0,18	0,12
<b>K0322.205</b>	M5	3	0,9	12	6	0,8	19	30	0,12	0,08
<b>K0322.206</b>	M6	3,5	1	14	7	1	28	40	0,43	0,21
<b>K0322.208</b>	M8	5	1,5	16	8	1,2	47	73	1,09	0,37
<b>K0322.210</b>	M10	6	2	19	9	1,6	66	100	1,36	0,62
<b>K0322.212</b>	M12	8	2,5	22	10	2	66	120	2,03	1,36
<b>K0322.216</b>	M16	10	3,5	24	14	2,5	90	180	3,95	2,95