

# Tiefspanner

## Artikelbeschreibung/Produktabbildungen



### Beschreibung

**Werkstoff:**  
Vergütungsstahl.

**Ausführung:**  
Grundkörper vergütet und brüniert.  
Spannbacke brüniert, an der Kante vergütet.

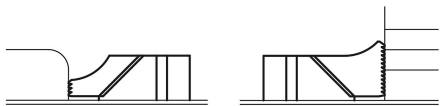
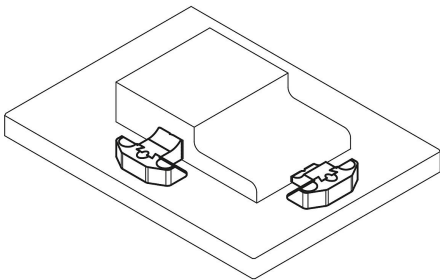

## Zeichnungen

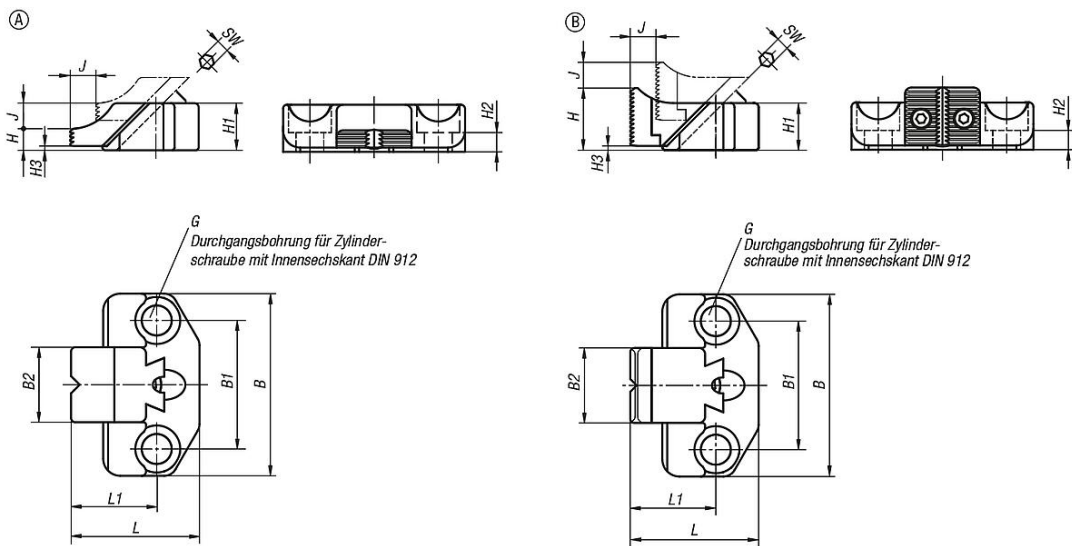

## Artikelübersicht

### Tiefspanner

Bestellnummer	Form	B	B1	B2	G	H	H1	H2	H3	J	L	L1	SW	Spannkraft N	Anzieh- drehmoment Nm
K0933.0808	A	65	45	25	M8	7,5	16	7	1,5	7	39,5	25	4	4000	8
K0933.1210	A	85	60	35	M12	10	22	9	2	12	60	40	6	9000	26
K0933.1614	A	100	70	40	M16	14	30	13	2	14	77	50	8	17000	60

## Artikelübersicht

Bestellnummer	Form	B	B1	B2	G	H	H1	H2	H3	J	L	L1	SW	Spannkraft N	Anzieh- drehmoment Nm
K0933.0820	B	65	45	25	M8	19,5	16	7	1,5	7	39,5	25	4	4000	8
K0933.1229	B	85	60	35	M12	29	22	9	2	12	60	40	6	9000	26
K0933.1638	B	100	70	40	M16	38	30	13	2	14	77	50	8	17000	60