

Link clamp, hydraulic double-acting

Item description/product images

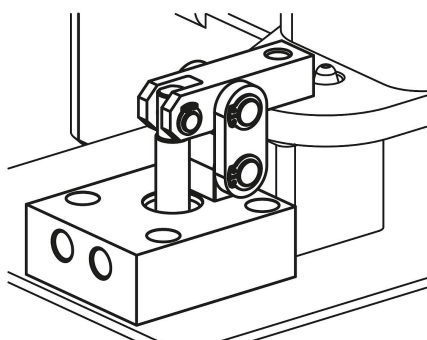

Description

Product description:

Link clamps are the optimal choice when, due to the clamping situation, the workpiece needs to be freely removed from above when unclamped. Due to the linear movement of the clamping lever when opening or closing the link clamp, it is particularly suitable for clamping situations where a lateral movement of the clamping element is not possible, e.g. due to interfering contours. The force is transferred to the tensioning lever of the link clamp via the piston. The opening and closing times are clearly defined due to the link clamps double-acting mode of operation.

Material:

Housing and piston steel.

Version:

Housing black oxidised.

Piston hardened.

Note:

The tensioning lever of the link clamp develops its optimum clamping force in the horizontal position.

Workpiece tolerances are compensated for up to a position deviation of $\pm 8.5^\circ$.

The clamping force of a link clamp is dependent on the lever length.

Follow safety instructions.

Type of operation:

- Thread connection.
- O-ring flange connection.
- Drilled channels.

Technical data:

- Max. operating pressure for piston diameters 16 and 25: 350 bar.
- Max. operating pressure for piston diameter 40: 200 bar.

Assembly:

See mounting contour.

Advantages:

- Integrated metal wiper.
- Partially retractable housing.
- Collision-free accessibility to the workpiece.
- Lineless pressure supply.
- Versatile mounting possibilities.

On request:

With position control.

Supplied with:

- 1x tension lever for link clamp.
- 4x DIN EN ISO 4762 cap screws grade 8.8.
- 4x Plastic caps.
- 2x O-rings 7x1.5 (for flange connection operating mode).

Drawing reference:

Link clamp, hydraulic double-acting

Item description/product images

H1* = optimum clamping point; from -1.5mm until tension lever contact

- 1) Mounting contour
- 2) Loosen
- 3) Clamp
- 4) Rounded edges
- 5) These holes are only closed with screw plugs by piston diameter 16

Drawings

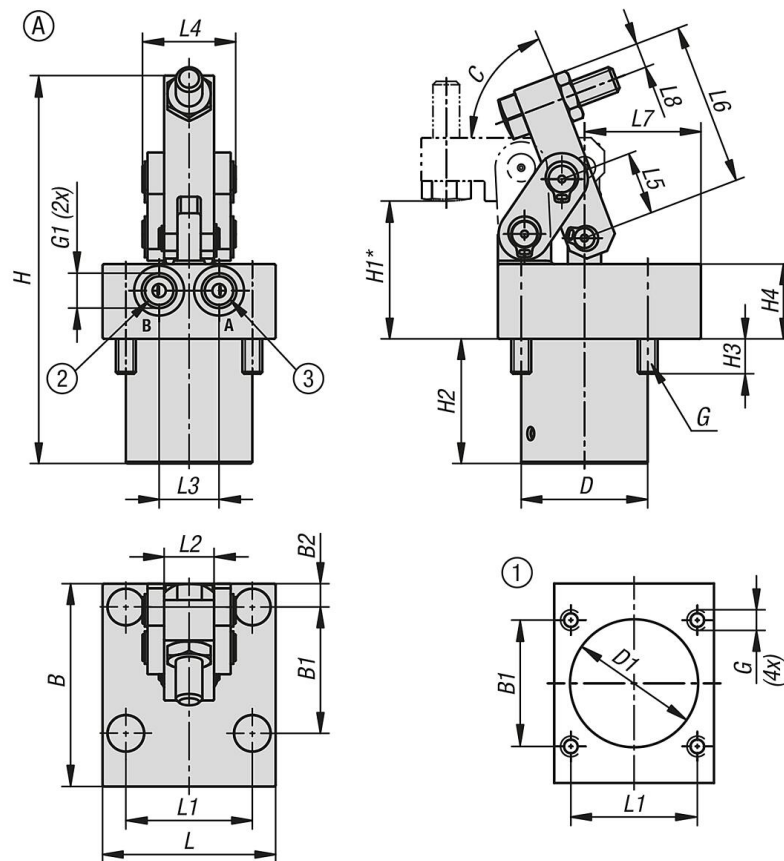

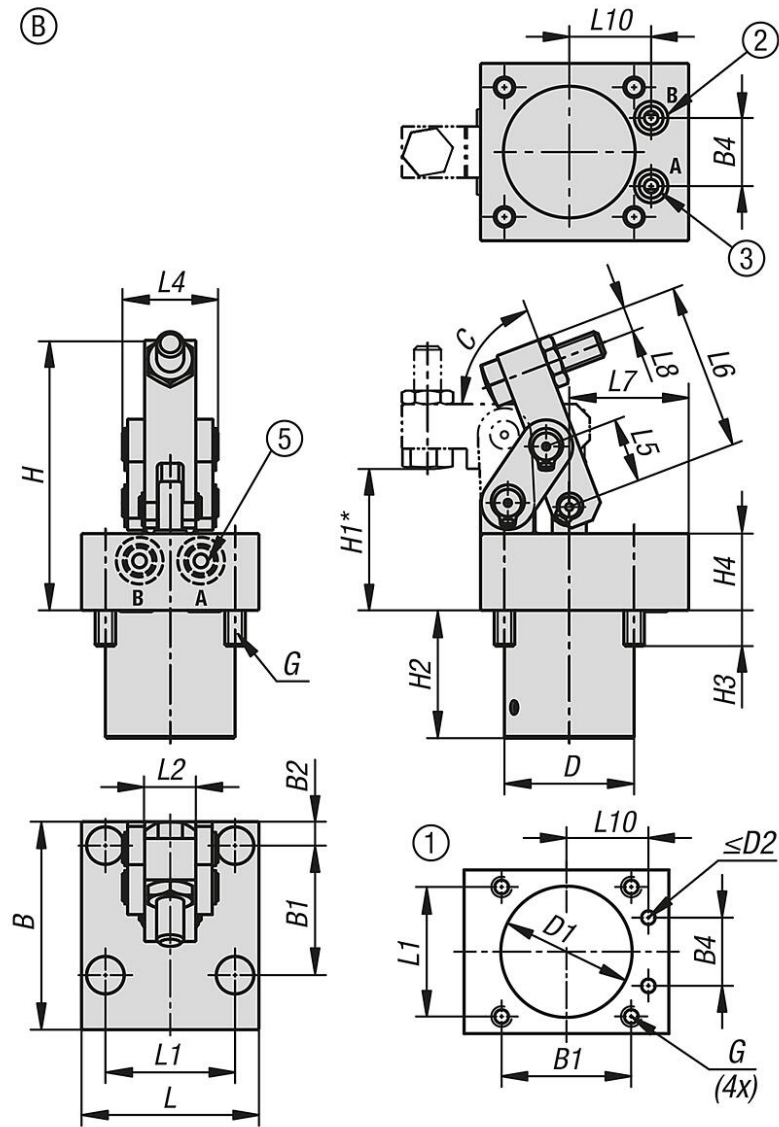

Link clamp, hydraulic double-acting

Drawings

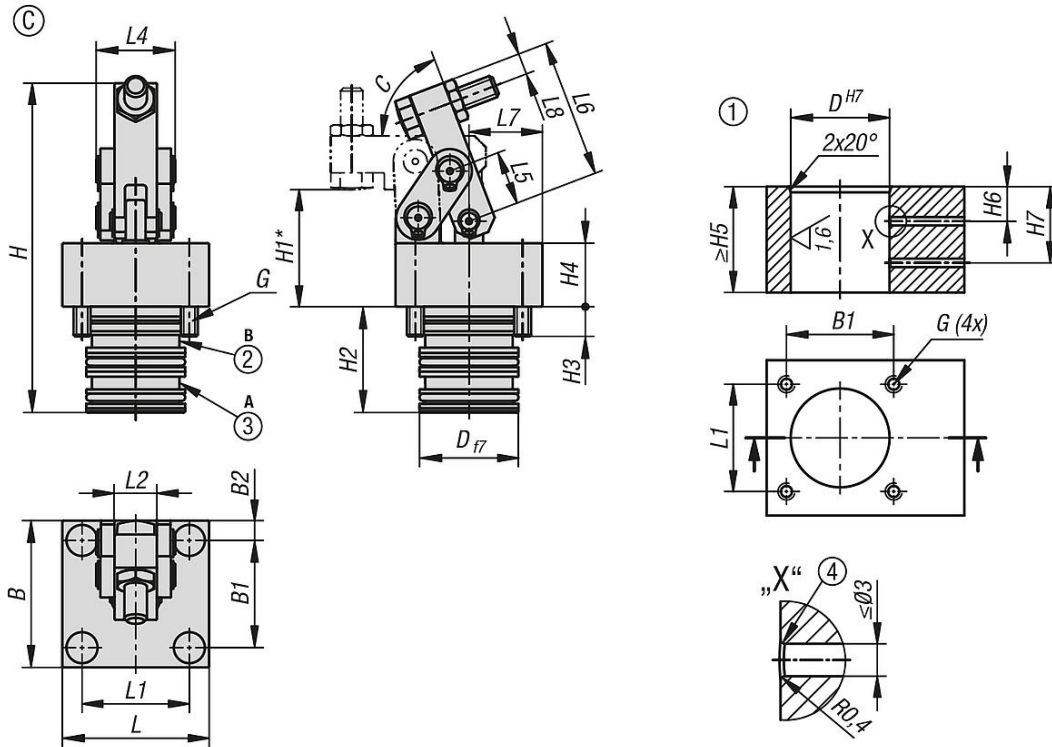

Clamping force diagram

Clamping force in relation to tension lever length L and operating pressure capacity p:

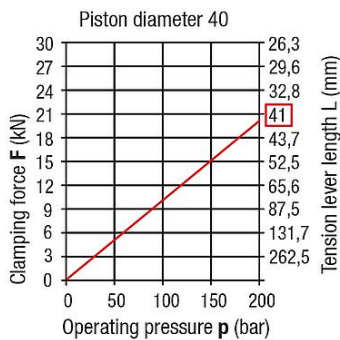
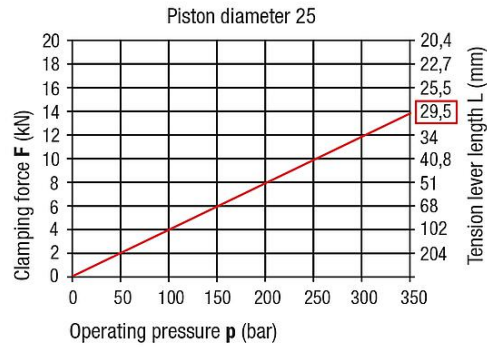
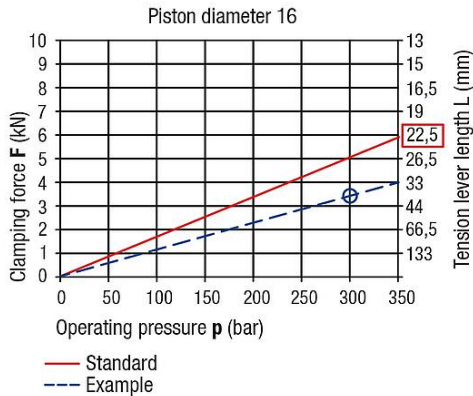

Example:

Values from diagram
 Max. operating pressure $p_{max.} = 350 \text{ bar}$
 $F_{max.}$ by $p_{max.}$ $F_{max.} = 4 \text{ kN}$
 Tension lever length $L = 33 \text{ mm}$
 Operating pressure $p = 300 \text{ bar}$
 Resulting clamping force $F = 3,43 \text{ kN}$

Calculation:

$$\text{Clamping force } F = F_{max.} \times \frac{p}{p_{max.}} = 4 \text{ kN} \times \frac{300 \text{ bar}}{350 \text{ bar}} = 3,43 \text{ kN}$$

Overview of items

Link clamp, hydraulic double-acting

Overview of items

Link clamp, hydraulic, double-acting

Order No.	Form	Piston Ø	Connection type	B	B1	B2	B4	C (degrees)	D	D1	D2	G	G1	H	H1	H2	H3	H4
K1858.161104	A	16	screw connection	61	38	7	-	69	38	38,5	-	M6x12	G1/8	117	41,5	37,5	10,5	22,5
K1858.251104	A	25	screw connection	80	56	8	-	65	50	50,5	-	M8x22	G1/4	156	50	54	19	22
K1858.401104	A	40	screw connection	85	62	13,5	-	65	70	70,5	-	M10x22	G1/4	191	65	67,7	20	25
K1858.161204	B	16	o-ring flange connection	61	38	7	20	69	38	38,5	4	M6x12	-	117	41,5	37,5	10,5	22,5
K1858.251204	B	25	o-ring flange connection	72	56	8	27	65	50	50,5	4	M8x22	-	156	50	54	19	22
K1858.401204	B	40	o-ring flange connection	95	62	13,5	29	65	70	70,5	5	M10x22	-	191	65	67,7	20	25
K1858.161304	C	16	drilled channels	52	38	7	-	69	35	-	-	M6x12	-	117	41,5	37,5	10,5	22,5
K1858.251304	C	25	drilled channels	72	56	8	-	65	50	-	-	M8x22	-	156	50	54	19	22
K1858.401304	C	40	drilled channels	85	62	13,5	-	65	70	-	-	M10x22	-	191	65	67,7	20	25

Order No.	Form	Piston Ø	H5	H6	H7	L	L1	L2	L3	L4	L5	L6	L7	L8	L10	Clamping force at 100 bar (kN)	Clamping force at 200 bar (kN)	Clamping force at 350 bar (kN)
K1858.161104	A	16	-	-	-	52	38	15	18	28	19	49	35	7,5	-	1,5	-	5,2
K1858.251104	A	25	-	-	-	72	56	24	25	44	24	63,5	44	10	-	3,9	-	13,8
K1858.401104	A	40	-	-	-	100	78	36	32	66	31,5	82,5	40,5	10	-	9,5	19	-
K1858.161204	B	16	-	-	-	52	38	15	-	28	19	49	35	7,5	24	1,5	-	5,2
K1858.251204	B	25	-	-	-	72	56	24	-	44	24	63,5	36	10	28,1	3,9	-	13,8
K1858.401204	B	40	-	-	-	100	78	36	-	66	31,5	82,5	50,5	10	42	9,5	19	-
K1858.161304	C	16	37,5	12,25	27	52	38	15	-	28	19	49	26	7,5	-	1,5	-	5,2
K1858.251304	C	25	55	25,2	41,8	72	56	24	-	44	24	63,5	36	10	-	3,9	-	13,8
K1858.401304	C	40	68	22-25	44-53	100	78	36	-	66	31,5	82,5	40,5	10	-	9,5	19	-