

## Tension levers for rotary lever clamps

### Item description/product images



### Description

#### Product description:

The tension lever can be used for the hydraulic rotary lever clamp K1856 or the pneumatic rotary lever clamp K1870. The "standard" tension lever or the "blank" tension lever can be selected. The "standard" tension lever is finish machined and can be mounted directly. The "blank" tension lever can be individually machined to suit. The blank lever is made from unhardened steel for easier machining. After the individual contour has been machined, the tension levers must be annealed and hardened before mounting to prevent deformation of the levers during use.

#### Material:

Standard and blank steel.

#### Version:

Standard hardened.

Blank not hardened.

#### Note:

By positioning the rotary lever clamp correctly, workpiece tolerances can be optimally compensated for despite the short clamping lever.

The clamping elements must be checked regularly for dirt and cleaned if necessary.

The effective clamping force must be calculated for every tension lever.

The optimum tension lever position is 90°.

The following hardness grade must be achieved before a "blank" tension lever is used: Hardened depth 0.3 + 0.2 HRC 50 +/- 2.

Follow safety instruction.

#### Assembly:

The tension lever is attached to the piston of the rotary lever clamp and secured with a dowel pin. The tension lever is thus axially secured and secured against rotation.

#### On request:

Other sizes and types.

#### Drawing reference:

Form A: Standard

Form B: Blank

# Tension levers for rotary lever clamps

## Drawings

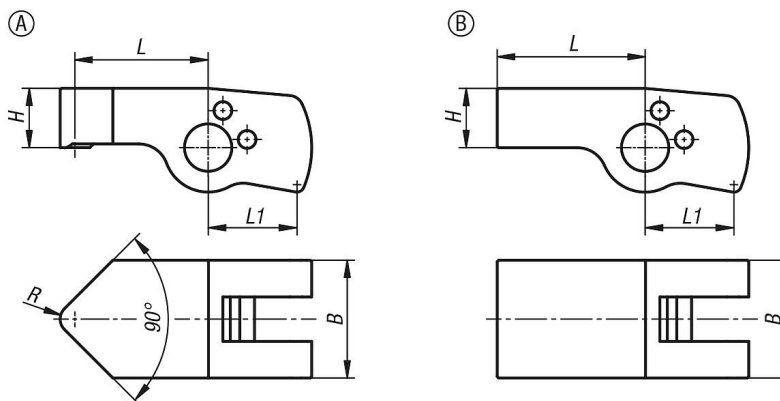

### Calculating the effective clamping force with hydraulic rotary lever clamps:

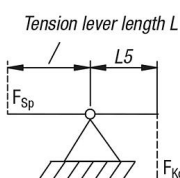

Effective clamping force  $F_{Sp}$  is dependent on piston force  $F_{Kol}$  and tension lever length  $L$

**Calculation:**  
 Clamping force  $F_{Sp} = \frac{F_{Kol} \times L5}{L}$   
 Clamping force  $F_{Sp} = \frac{2.5 \text{ kN} \times 10 \text{ mm}}{18 \text{ mm}} = 1.39 \text{ kN}$

**Example:**  
 Rotary lever clamp cylinder size 16  
 Operating pressure 100 bar  
 Piston force  $F_{Kol}$  at 100 bar = 2.5 kN  
 Dimension L5 acc. to table = 10 mm  
 Tension lever length  $L = 18 \text{ mm}$   
 Resulting effective clamping force  $F_{Sp} = 1.39 \text{ kN}$

### Calculating the effective clamping force with pneumatic rotary lever clamps:

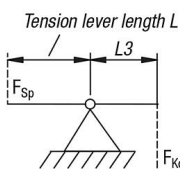

Effective clamping force  $F_{Sp}$  is dependent on piston force  $F_{Kol}$  and tension lever length  $L$

**Calculation:**  
 Clamping force  $F_{Sp} = \frac{F_{Kol} \times L3}{L}$   
 Clamping force  $F_{Sp} = \frac{1.99 \text{ kN} \times 25 \text{ mm}}{45 \text{ mm}} = 1.11 \text{ kN}$

**Example:**  
 Rotary lever clamp cylinder size 40  
 Operating pressure 6 bar  
 Piston force  $F_{Kol}$  at 6 bar = 1.99 kN  
 Dimension L3 acc. to table = 25 mm  
 Tension lever length  $L = 45 \text{ mm}$   
 Resulting effective clamping force  $F_{Sp} = 1.11 \text{ kN}$

## Overview of items

### Tension levers for rotary lever clamps

Order No.	Form	Form definition	For piston Ø	travel	B	H	L	L1	R
K1857.12091	A	standard	12	0,98	12	6	9	9	1,5
K1857.12131	A	standard	12	1,12	12	6	13,5	9	1,5
K1857.12181	A	standard	12	1,97	12	6	18	9	1,5
K1857.12221	A	standard	12	2,45	12	6	22,5	9	1,5
K1857.16121	A	standard	16	0,78	16	8	12	12	2
K1857.16181	A	standard	16	1,16	16	8	18	12	2
K1857.16241	A	standard	16	1,6	16	8	24	12	2
K1857.16301	A	standard	16	1,94	16	8	30	12	2
K1857.20151	A	standard	20	1,48	20	10	15	15	2,5
K1857.20221	A	standard	20	2,21	20	10	22,5	15	2,5

## Tension levers for rotary lever clamps

### Overview of items

Order No.	Form	Form definition	For piston Ø	travel	B	H	L	L1	R
K1857.20301	A	standard	20	2,95	20	10	30	15	2,5
K1857.20371	A	standard	20	3,68	20	10	37,5	15	2,5
K1857.25191	A	standard	25	1,26	25	12,5	19	18,8	3
K1857.25281	A	standard	25	1,86	25	12,5	28	18,8	3
K1857.25381	A	standard	25	2,52	25	12,5	38	18,8	3
K1857.25471	A	standard	25	3,12	25	12,5	47	18,8	3
K1857.32241	A	standard	32	2,56	32	16	24	24	4
K1857.32361	A	standard	32	3,85	32	16	36	24	4
K1857.32481	A	standard	32	5,13	32	16	48	24	4
K1857.32601	A	standard	32	6,4	32	16	60	24	4
K1857.40301	A	standard	40	3,05	40	20	30	30	5
K1857.40451	A	standard	40	4,6	40	20	45	30	5
K1857.40601	A	standard	40	6,1	40	20	60	30	5
K1857.40751	A	standard	40	7,6	40	20	75	30	5
K1857.12152	B	blank	12	1,64	12	6	15	9	-
K1857.12242	B	blank	12	2,62	12	6	24	9	-
K1857.16202	B	blank	16	1,29	16	8	20	12	-
K1857.16322	B	blank	16	2,07	16	8	32	12	-
K1857.20252	B	blank	20	2,45	20	10	25	15	-
K1857.20402	B	blank	20	3,92	20	10	40	15	-
K1857.25312	B	blank	25	2,1	25	12,5	31	18,8	-
K1857.25502	B	blank	25	3,32	25	12,5	50	18,8	-
K1857.32402	B	blank	32	4,28	32	16	40	24	-
K1857.32642	B	blank	32	6,84	32	16	64	24	-
K1857.40502	B	blank	40	5,08	40	20	50	30	-
K1857.40802	B	blank	40	8,1	40	20	80	30	-