

Locating bushes, stainless steel for status sensor, for ball lock pins with twist knob

Item description/product images

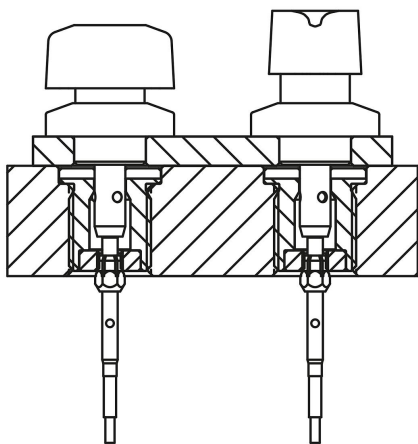

Description

Product description:

Locating bushes form a locating point for ball lock pins with twist knobs and enable these to be securely and precisely engaged herein.

The locating bushes for status sensor have a locknut for installing a $\varnothing 3$ mm sensor into the bush. The sensor enables electronic feedback as to whether a ball lock pin with twist knob is locked or not.

When using several bushes, it can be determined in which one a ball lock pin is located.

Material:

Locating bush stainless steel 1.4305.

Locknut brass.

Version:

Locating bush bright.

Locknut nickel-plated.

Note:

The locknut is supplied loose.

Max. tightening torque for the locknut: 1.2 Nm.

Application:

Locating bushes in conjunction with a status sensor enable actuation-dependent process control. In addition, it can be determined whether a ball lock pin or locking pin is in the desired position.

Assembly:

The sensor is fastened into the bush using the locknut and then adjusted axially. The locknut is tightened to fixate the sensor in the final position.

The detailed procedure is described in the installation instructions.

Locating bushes, stainless steel for status sensor, for ball lock pins with twist knob

Drawings

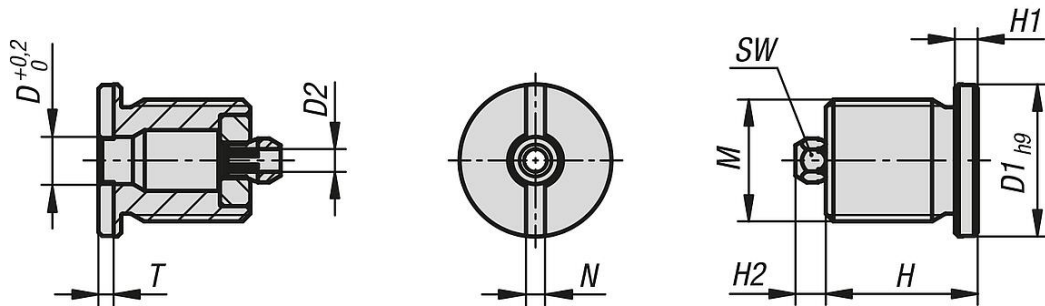

Overview of items

Locating bushes, stainless steel for status sensor

Order No.	Form	Form definition	D	D1	D2	M	H	H1	H2	N	T	SW
K1844.1206161	B	with thread and collar for BLP with twist knob	6,2	20	3	M16x1,5	20	3	4	2,5	2	5
K1844.1210201	B	with thread and collar for BLP with twist knob	10,2	25	3	M20x1,5	23	3	4	2,5	2	5