

Indexing plungers, steel with plastic twist knob and tapered indexing pin

Item description/product images

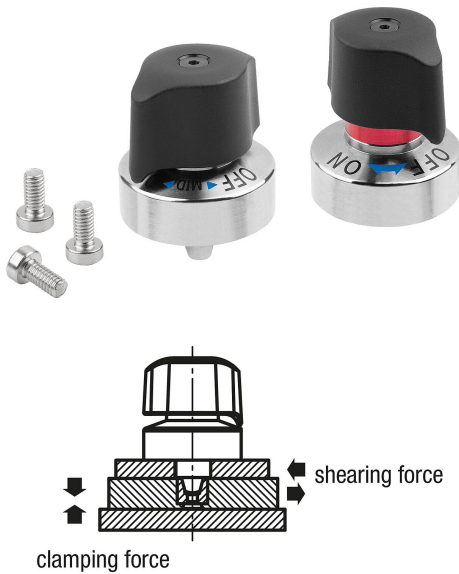

Description

Material:

Housing and pin steel.

Locked mark.

Twist knob thermoplastic PA (polyamide)

Version:

Housing and pin nickel plated.

Locked mark anodised, red.

Twist knob fiberglass reinforced, black.

Note:

Indexing plungers are used where any change in locking position due to lateral forces should be prevented.

If the locked mark is visible, the pin is either completely retracted or only partly in the indexed position.

Mounting option 1 for plate thickness 6 mm.

Mounting option 2 by Form A for plate thickness > 6 up to 14 mm and by Form B for plate thickness > 6 up to 15 mm.

Type of operation:

Style A:

Check that the twist knob is in the "OFF" position and that the pin is retracted.

Slide the plate with the bushing under the indexing plunger.

To clamp, turn the twist knob to the "ON" position.

When fully clamped, an audible click will be heard.

Caution: Do not loosen the clamping of the indexing plunger when the pin is under an axial load. Due to the conical shape, the pin may not retract.

Style B:

With the twist knob in the "OFF" position, slide the plate with the bushing towards the indexing plunger until the spring locks the pin into the bushing.

The twist knob will move automatically to the "MID" position.

For complete clamping, turn the twist knob from the "MID" position to the "ON" position until a click signal is heard.

Supplied with:

Fastening screws are supplied.

Accessory:

Drill bushings K1835.

Drawing reference:

- 1) Mounting option 1
- 2) Mounting option 2
- 3) Plate
- 4) ON position
- 5) OFF position
- 6) Locked mark

Indexing plungers, steel with plastic twist knob and tapered indexing pin

Drawings

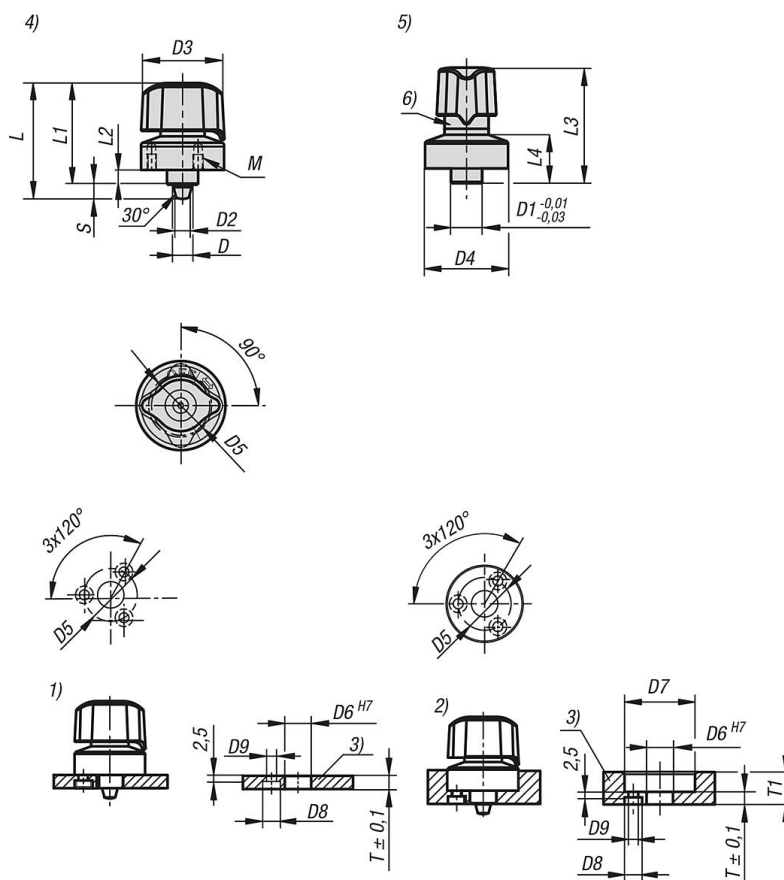

Overview of items

Indexing plungers steel, with twist knob and tapered indexing pin

Order No.	Form	Form definition	D	D1	D2	D3	D4	D5	D6	D7	D8	D9	T	T1	L	L1	L2	L3	L4
K1834.0005	A	-	5	10	3,3	26	26	20	10	-	6,5	3,4	6	6-14	38,9	29	5,7	33	11
K1834.0007	A	-	7	12	4,9	32	32	24	12	-	8	4,5	6	6-15	44,7	34	5,7	39	13
K1834.0107	B	-	7	12	4,9	32	32	24	12	-	8	4,5	6	6-15	44,7	34	5,7	39	13

Order No.	Form	Travel S	Clamping force N	F= Spring strength (N)	Temperature resistance	Shearing force kN	M
K1834.0005	A	4,2	140	-	80 °C	0,9	M3x5
K1834.0007	A	5	170	-	80 °C	1,3	M4x6
K1834.0107	B	5	170	9	80 °C	1,3	M4x6