

## Fixed jaws ES for multi-clamping system

### Item description/product images

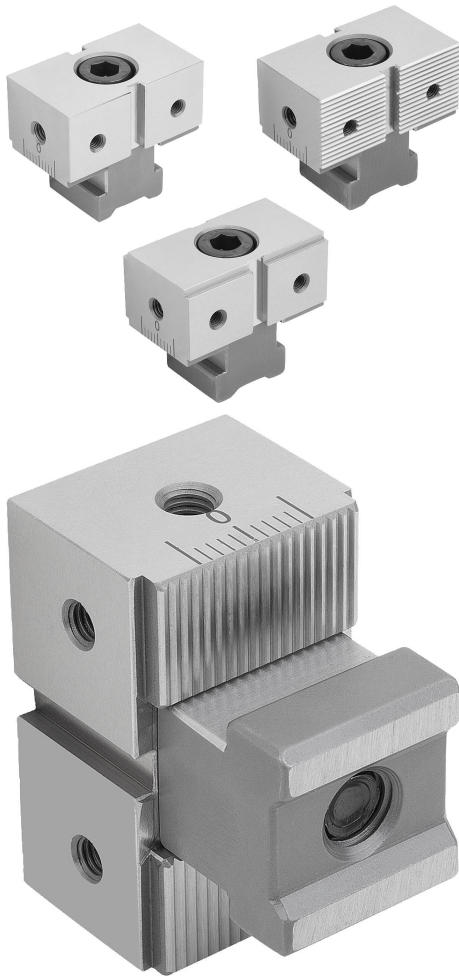

### Description

**Material:**  
Tool steel.

**Version:**  
Hardened and ground (HRC 55 ±2).

**Note:**

There are three different fixed jaw versions to choose from:

- Smooth version Form A for pre-machined workpieces.
- Serrated version Form B for raw parts.
- Offset jaws Form C for clamping with a small clamping edge.

The lateral fastening holes are used to fasten workpiece end stops. The two screw-on holes on the clamping surfaces also allow seating ledges to be mounted so as to optimise the clamping depth of the workpieces.

**Application:**

The ES fixed jaws are positioned on the clamping rails according to the clamping situation. When the fastening screw is tightened, the toothing allows a form-fit connection to be created. This allows high retaining forces to be carried through the clamping elements. With its slim design, the ES fixed jaw is especially suitable for clamping processes with smaller workpieces and large batch sizes. This also means that large production batches can be processed economically.

**Advantages:**

The lateral scale on the clamping rails and the fixed jaws allows precise positioning of the fixed stops.

**Supplied with:**

- ES fixed jaw.
- Fastening screw.
- Slot key.

### Drawings

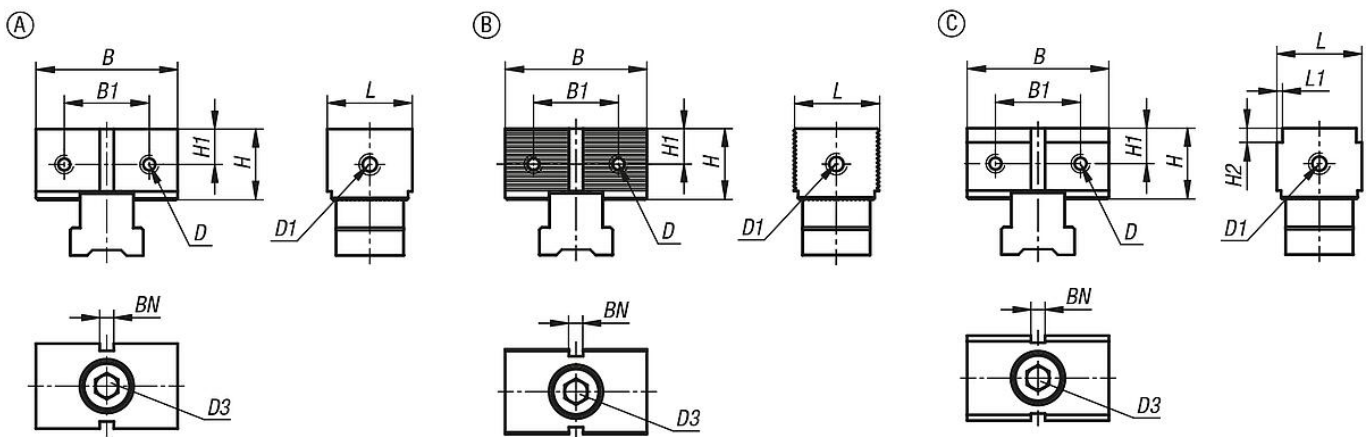

### Overview of items

### Fixed jaws ES for multi-clamping system

## Fixed jaws ES for multi-clamping system

### Overview of items

Order No.	suitable for system width	Form	Form definition	L	B	H	L1	B1	H1	H2	D Internal thread	D1 internal thread	D3	BN=Slot width
K1750.0503001	50	A	smooth	30	50	25	-	30	12,5	-	M5	M6	M10x30	5
K1750.0503002	50	B	serrated	30	50	25	-	30	12,5	-	M5	M6	M10x30	5
K1750.0503023	50	C	stepped	30	50	25	2	30	12,5	2	M5	M6	M10x30	5
K1750.0503053	50	C	stepped	30	50	25	2	30	12,5	5	M5	M6	M10x30	5