

Antistatic protective caps

Item description/product images

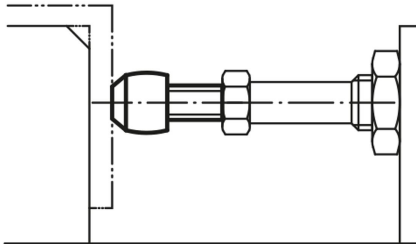

Description

Material:

Neoprene.

Version:

Neoprene black, oil resistant, Shore hardness 75A.

Application:

Sensitive electrical or electronic equipment, components and devices (ESD sensitive elements) may be damaged or destroyed by electrostatic discharges (ESD) in the immediate vicinity.

Electrostatic discharges can come from people or through handling ESD sensitive components (e.g. during production, assembly, transport, storage etc).

Electrically conductive products which conform to DIN EN 61340-5-1 are essential within electronic environments to prevent an electrostatic discharge.

These products can be used for ESD applications or in ESD protection areas (EPA) in accordance with DIN EN 61340-5-1.

Advantages:

- Made from a special electrically conductive plastic
- To protect sensitive electrical or electronic parts, components and devices

Safety:

These ESD products can also be used for devices, components and protection systems in areas where there is risk of explosion.

These ESD products prevent electrostatic spark discharges, and eliminate the risk of ignition of gases and dust which could lead to explosions in enclosed spaces.

Manufacturers and operators must apply and comply with the ATEX directives for protecting persons working in areas where there is a risk of explosion.

Target groups:

Device manufacturers required to conform to ATEX product directive 2014/34/EU.

Operators required to conform to ATEX worker protection directive 1999/92/EC.

Antistatic protective caps

Drawings

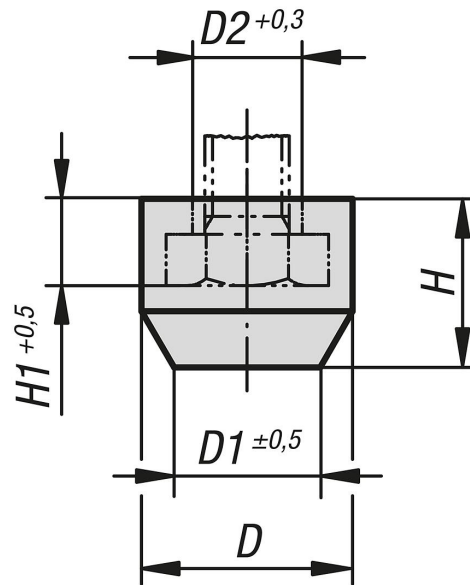

Overview of items

Antistatic protective caps

Order No.	D	D1	D2	H	H1	for screws
K0106.0124	11	6,6	5,5	8,5	4	M4
K0106.0224	12,5	7,3	6,8	10	4,7	M5
K0106.0324	15	9,9	8,5	12	5,8	M6
K0106.0424	19	12,7	11,3	15	7,1	M8