

Ratchet elements, Form C with internal tothing

Item description/product images

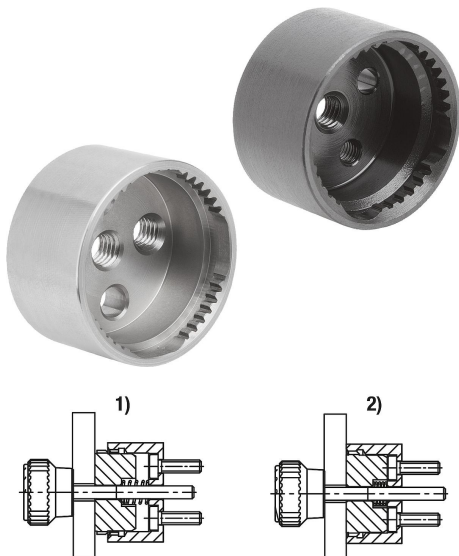

Description

Product description:

Ratchet elements are used to connect two components together in any angular position with a positive fit. The ratchet elements with internal tothing (Forms A–D) can be combined with the ratchet elements with external tothing (Forms E–H) in any way depending on the application and installation possibilities. The springs mean that a new angular position can be quickly implemented.

Material:

Ratchet element steel 1.0718 or stainless steel 1.4305.

Spring stainless steel 1.4310.

Cap screws steel or stainless steel A 2.

Version:

Ratchet element black oxidised steel or bright stainless steel.

Spring bright.

Cap screw blackened steel grade 8.8 or bright A2-70 stainless steel.

Note for ordering:

2 cap screws M3x8 or M5x10 are supplied with the internal toothed ratchet elements Forms A and B.

A stainless steel spring is supplied with the external toothed ratchet elements Forms E to H.

Note:

Use DIN 7984 low headed cap screws for fastening the Form A and B ratchet elements.

Function:

The ratchet elements are used for rotary adjustment of components. Fastening options can be arranged according to the application.

Drawing reference:

1) disengaged

2) engaged

Drawings

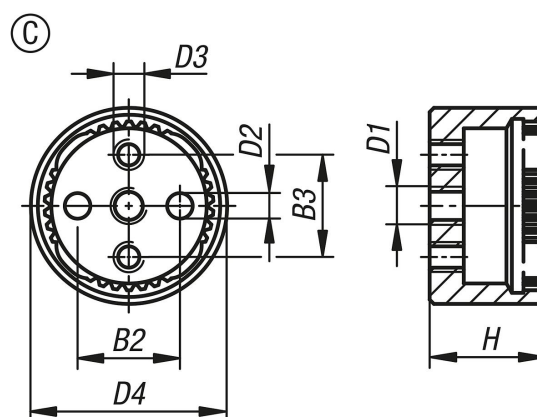

Ratchet elements, Form C with internal toothing

Overview of items

Order No.	Form	Main material	B2	B3	D1	D2	D3	D4	H	No. of teeth
K1446.32338	C	steel	12	12	M4	3H8	M3	23	13,5	38
K1446.33346	C	steel	18	18	M6	5H8	M5	33	19,5	46
K1446.132338	C	stainless steel	12	12	M4	3H8	M3	23	13,5	38
K1446.133346	C	stainless steel	18	18	M6	5H8	M5	33	19,5	46