

Self-aligning pads with locknut, Form C, flattened ball smooth

Item description/product images



Description

Material:

Steel or stainless steel.

Version:

Steel version:

Housing tempered and manganese phosphated.

Nut black oxidised.

Stainless steel version:

Housing tempered and electropolished.

Nut bright.

Note:

Ball secured against rotation.

Drawings

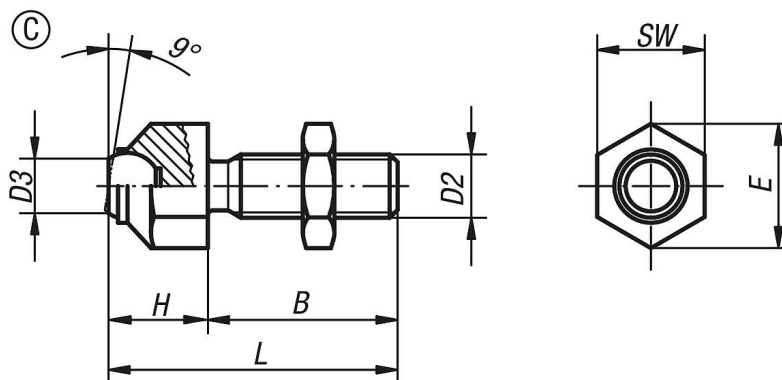

Overview of items

Order No.	Form	Main material	B	D2	D3	H	L	E	SW	Ball-Ø	Load rating max. kN (static load only)
K0287.108	C	steel	25	M8	5,8	11,6	36,6	14,5	13	8,5	8
K0287.110	C	steel	30	M10	8,6	15,7	45,7	19	17	12	8
K0287.112	C	steel	35	M12	8,6	15,7	50,7	19	17	12	15
K0287.116	C	steel	40	M16	10,5	20,7	60,7	27	24	16	25
K0287.120	C	steel	50	M20	20	27,3	77,3	33	30	25	90
K0287.1081	C	stainless steel	25	M8	5,8	11,6	36,6	14,5	13	8,5	8
K0287.1101	C	stainless steel	30	M10	8,6	15,7	45,7	19	17	12	8
K0287.1121	C	stainless steel	35	M12	8,6	15,7	50,7	19	17	12	15
K0287.1161	C	stainless steel	40	M16	10,5	20,7	60,7	27	24	16	25
K0287.1201	C	stainless steel	50	M20	20	27,3	77,3	33	30	25	90

Self-aligning pads with locknut, Form C, flattened ball smooth

Overview of items
