

Rest pads, Form C serrated face

Item description/product images



Description

Material:

Body high carbon steel.

Version:

Body tempered and black oxidised.

Note:

Rest pads are for supporting machined and non-machined parts. They can also be used as stops and thrust pads in fixtures and toolmaking.

Studs or grub screws can be screwed and glued into the tapped hole D to make a rest pad with external thread.

Drawings

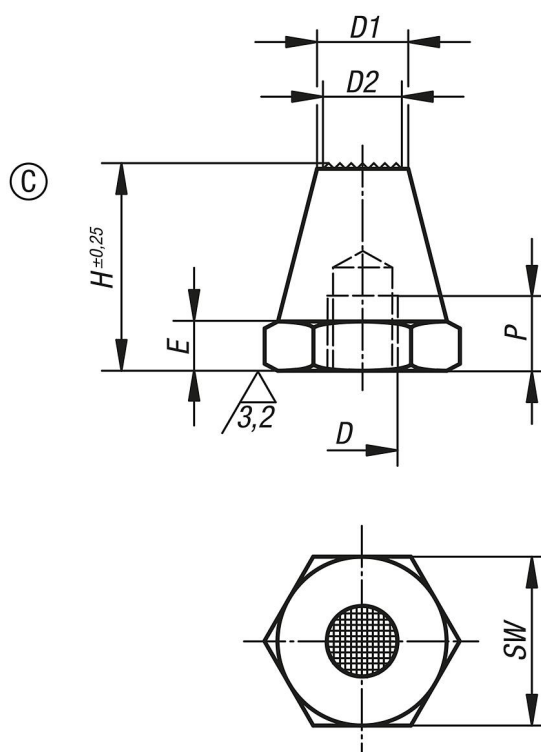

Overview of items

Order No.	Form	D	D1	D2	E	H	P	SW
K0294.306012	C	M6	6	5	3	12,5	4	11
K0294.306025	C	M6	6	5	3	25	7	11
K0294.308015	C	M8	8	6	4	15	6	13
K0294.308030	C	M8	8	6	4	30	9	13
K0294.310020	C	M10	10	8	5	20	9	17
K0294.310040	C	M10	10	8	5	40	13	17

Rest pads, Form C serrated face

Overview of items

Order No.	Form	D	D1	D2	E	H	P	SW
K0294.312025	C	M12	12	9,5	6	25	11	19
K0294.312050	C	M12	12	9,5	6	50	16	19
K0294.316030	C	M16	16	13	8	30	12	24
K0294.316060	C	M16	16	13	8	60	20	24